



# CELEBRITY Owner's Manual

Marquis® | Las Vegas, NV

**CONGRATULATIONS ON YOUR NEW CELEBRITY HOT TUB!**

We sincerely hope your spa life is a pleasant experience. If a problem should arise, contact your authorized Marquis Hot Tubs/Celebrity Hot Tubs dealer or by following the information listed below. contact Celebrity Hot Tubs at any of the following:

**Email:**

service@marquiscorp.com

**Web:** www.MarquisSpas.com**Marquis Hot Tubs, LLC**

4720 N Lamb Blvd

Las Vegas, NV 89115

This manual is provided to enhance your safety and enjoyment of your spa and to prevent non-warranty situations. It is your sole responsibility to read, understand and comply with the instructions in the owner's manual. Please save your original sales receipt for reference in case of a future warranty claim. Failure to use, maintain or install the spa in compliance with this owner's manual could result in loss of warranty coverage.

**SERIAL NUMBER LOCATION**

You will find the serial number on the tag in the equipment area.

**PLEASE FILL OUT AND KEEP FOR FUTURE REFERENCE****Name of Purchaser** \_\_\_\_\_**Date of Purchase** \_\_\_\_\_**Address** \_\_\_\_\_**City** \_\_\_\_\_ **State** \_\_\_\_\_ **Zip Code** \_\_\_\_\_**Telephone** \_\_\_\_\_**Spa Model/Color** \_\_\_\_\_**Spa Serial #** \_\_\_\_\_**Pack Serial #** \_\_\_\_\_**Dealer's Name** \_\_\_\_\_**Dealer's Address** \_\_\_\_\_**City** \_\_\_\_\_ **State** \_\_\_\_\_ **Zip Code** \_\_\_\_\_**Telephone** \_\_\_\_\_

Every effort has been made to ensure the accuracy of this manual. However, Marquis Hot Tubs, LLC and, Celebrity Hot Tubs reserve the right to improve its product without notice. This could create a minor variation between this manual and the actual product you receive. We apologize for any inconvenience this may cause.

## **CELEBRITY HOT TUBS OWNER'S MANUAL INDEX**

READ AND FOLLOW ALL INSTRUCTIONS! .....	3
240 VOLT, PERMANENTLY INSTALLED OR CONVERTED MODELS .....	4
SAVE THESE INSTRUCTIONS.....	5
PERSONAL SAFETY DOs: .....	7
PERSONAL SAFETY DO NOTs: .....	8
INSTALLATION INSTRUCTIONS .....	12
STARTING YOUR SPA .....	14
STARTUP PROCEDURE .....	16
OPERATING THE ELECTRONIC CONTROLS .....	19
CELEBRITY HOT TUBS MODELS DIAGRAMS .....	22
THE WOODSTOCK™ .....	22
WOODSTOCK™ ZONES .....	23
THE VEGAS™ .....	24
THE VEGAS™ ZONES .....	25
THE HOLLYWOOD™ .....	26
THE HOLLYWOOD™ ZONES .....	27
BROADWAY™ ZONES .....	28
THE BROADWAY™ ZONES .....	29
MONACO™ .....	30
THE MONACO™ ZONES .....	31
THE NASHVILLE™ .....	32
THE NASHVILLE™ ZONES.....	33
WOODSTOCK EQUIPMENT .....	34
VEGAS & HOLLYWOOD EQUIPMENT.....	35
BROADWAY EQUIPMENT .....	36
NASHVILLE EQUIPMENT.....	37
MONACO EQUIPMENT .....	38
LCD DIAGNOSTIC MESSAGES .....	41
IMPORTANT CHEMICAL SAFETY PROCEDURES .....	48

**IMPORTANT SAFETY INFORMATION!  
READ, AND FOLLOW, AND SAVE THESE  
INSTRUCTIONS!**

**THIS PRODUCT SHALL BE INSTALLED IN  
ACCORDANCE WITH ALL LOCAL CODES**

**THIS PRODUCT SHALL BE SECURED TO  
PROTECT AGAINST UNAUTHORIZED  
ACCESS PER LOCAL CODES**

**WHEN INSTALLING AND USING THIS  
ELECTRICAL EQUIPMENT, THESE BASIC  
SAFETY PRECAUTIONS SHOULD ALWAYS  
BE FOLLOWED INCLUDING THE  
FOLLOWING:**

1. **WARNING:** To reduce the risk of injury, do not permit children to use this product unless closely supervised at all times.
2. **DANGER: RISK OF ACCIDENTAL DROWNING.** Extreme caution must be exercised to prevent unauthorized access by children. To avoid accidents, ensure that children cannot use the spa or hot tub unless they are supervised at all times. Be sure to close and lock the cover after each use.

**120 VOLT, GFCI CORD CONNECTED MODELS**

3. **DANGER: RISK OF INJURY.** Connect only to a grounded source.
4. Do not bury the power cord.
5. **WARNING:** To reduce the risk of electric shock, replace the damaged cord immediately.
6. **WARNING:** 120 Volt Cord GFCI Connected Units. Your spa may be equipped with a Ground Fault Circuit Interrupter (GFCI) at the end of the power supply cord. Before each use of the spa, with the plug connected to the power supply and the unit operating, press the “test” button. The unit should stop operating and the GFCI power indicator will go out. Wait thirty seconds and then reset the GFCI by pressing the “Reset” button. The GFCI power indicator will turn on, restoring power to the spa. If the interrupter does not perform in this manner, it is an indication of an electrical malfunction and the possibility of an electric shock. Disconnect the plug from the receptacle until the fault has been identified and corrected

**240 VOLT, PERMANENTLY INSTALLED OR CONVERTED MODELS**

7. A ground terminal is provided on the control box located in the equipment bay of the spa. To reduce the risk of electric shock, connect this terminal to the grounding terminal of your electrical service or supply panel with a continuous green, insulated copper wire. The wire must be equivalent in size to the circuit conductors supplying the equipment. In addition a bonding terminal (pressure wire connector) is provided on the outside of the control box for bonding to local ground points. To reduce the risk of electric shock, this connector should be bonded with a No. 8 AWG (8.42mm<sup>2</sup>) (No. 6 AWG in Canada) solid copper wire to any metal ladders, water pipes, or other metal within five feet (1.52m) of the spa to comply with local requirements. If the spa is located on a reinforced concrete pad, the reinforcing steel should also be bonded to the ground terminal.
8. Your spa uses requires a ground fault circuit interrupters in the electrical sub-panel. Before each use of the spa and with the unit operating press the “Test” button on each the breaker. The switch breaker should click over to the “Trip.” position. Wait thirty seconds and reset each the GFCI breaker by switching it completely off and then completely on. The switch should then stay on. If either of the interrupters does not perform in this manner, it is an indication of an electrical malfunction and the possibility of an electric shock. Disconnect the power until the fault has been identified and corrected.

## **ALL SPA MODELS**

9. Install the spa so proper drainage is provided.
10. **DANGER: RISK OF ELECTRIC SHOCK.** Install the spa at least five feet (1.52m) away from metal surfaces. As an alternative, a spa may be installed within 5 feet of metal surfaces if each metal surface is permanently connected by a minimum 8 AWG (8.4mm<sup>2</sup>) solid copper conductor to the wire connector on the terminal box that is provided for this purpose.

11. **DANGER: RISK OF ELECTRIC SHOCK.** Do not permit any appliance, such as a light, telephone, radio, or television, etc. within five feet (1.52m) of the spa or hot tub.
12. **WARNING:** To reduce the risk of injury:
13. The water in the spa should never exceed 40°C (104°F). Water temperatures between 100°F (38°C) and 104°F (40°C) are considered safe for a healthy adult. Lower water temperatures are recommended for young children and when spa use exceeds 10 minutes.
14. Since excessive water temperatures have a high potential for causing fetal damage during the early months of pregnancy, pregnant or possibly pregnant women should limit spa water temperatures to 38°C (100°F).
15. Before entering a spa, the user should measure the water temperature since the tolerance of water temperature-regulating devices varies
16. The use of drugs, alcohol, or medication before or during spa use may lead to unconsciousness with the possibility of drowning.
17. Persons and persons with a history of heart disease, low or high blood pressure, circulatory system problems, or diabetes should consult a physician before using the spa.
18. Persons using medications should consult a physician before using a spa since some medication may induce drowsiness while other medication may affect heart rate, blood pressure, and circulation.
19. **DANGER: TO REDUCE THE RISK OF INJURY TO PERSONS.** Do not remove the suction fittings.
20. **DANGER: RISK OF INJURY:** Never operate a spa if the suction guard(s) is broken or missing. Never replace a suction guard with one rated less than the flow rate marked on the original suction guard. The suction guard(s) in the spa are sized to match the specific water flow created by the pump. Should the need arise to replace the suction guard(s) or the pump, be sure that the flow rates are compatible.
21. **DANGER:** Children are especially sensitive to hot water. At no time should children have unsupervised access to the spa. Children must not be allowed to climb onto the spa cover. All hot tubs are equipped with a locking cover that meets the ASTM F1346-91 Standard for Safety Covers. Always lock the child resistant locks after using the spa for your children's safety.

### **SAVE THESE INSTRUCTIONS.**

**WARNING:** Do not permit electric appliances (such as a light, telephone, radio, or television) within five feet (1.52m) of the spa or hot tub.

**WARNING:** Children should not use spas or hot tubs without adult supervision.

**WARNING:** Do not use spas or hot tubs unless all suction guard(s) are installed to prevent body and hair entrapment.

**WARNING:** Do not use drugs or alcohol before or during the use of a spa or hot tub to avoid unconsciousness and possible drowning.

**WARNING:** People using medications and/or having an adverse medical history should consult a physician before using a spa.

**WARNING:** The use of alcohol, drugs, and medication can greatly increase the risk of fatal hyperthermia.

**WARNING:** Before entering the spa or hot tub, measure the water temperature with an accurate thermometer.

**WARNING:** Water temperature in excess of 104°F (40°C) may be injurious to your health.

**WARNING:** Prolonged immersion in a spa or hot tub may be injurious to your health.

**WARNING:** People with infectious diseases should not use a spa.

**WARNING:** Pregnant or possibly pregnant women should consult a physician before using a spa or hot tub.

**WARNING:** To avoid injury, exercise when entering and exiting the spa or hot tub.

**WARNING:** Do not use a spa or hot tub immediately following strenuous exercise.

**WARNING:** Maintain water chemistry in accordance with manufacturer's instructions.

#### **SAFETY INSTRUCTIONS FOR FRENCH SPEAKING SPA OWNERS**

**AVERTISSEMENT:** Ne pas placer d'appareil électrique (luminaire, téléphone, radio, téléviseur, etc.) moins de 1.52 m de cette cuve de relaxation. **AVERTISSEMENT:** Ne pas laisser les enfants utiliser une cuve de relaxation sans surveillance.

**AVERTISSEMENT:** Pour éviter que les cheveux ou une partie du corps puissent être aspirés, ne pas utiliser une cuve de relaxation si les grilles de prise d'aspiration ne sont pas toutes en place.

**AVERTISSEMENT:** Pour éviter l'évanouissement et la noyade éventuelle, ne prendre ni drogue ni alcool avant d'utiliser une cuve de relaxation ni quand on s'y trouve.

**AVERTISSEMENT:** Les personnes qui prennent des médicaments ou ont des problèmes de santé devraient consulter un médecin avant d'utiliser une cuve de relaxation.

**AVERTISSEMENT:** La consommation d'alcool ou de drogue augmente considérablement les risques d'hyperthermie motelle dans une cuve de relaxation.

**AVERTISSEMENT:** Avant d'utiliser une cuve de relaxation mesurer la température de l'eau l'aide d'un thermomètre précis.

**AVERTISSEMENT:** Il peut être dangereux pour la santé de se plonger dans de l'eau plus de 40°C.

**AVERTISSEMENT:** L'utilisation prolongée d'une cuve de relaxation peut être dangereuse pour la santé.

**AVERTISSEMENT:** Les personnes atteintes de maladies infectieuses ne devraient pas utiliser une cuve de relaxation.

**AVERTISSEMENT:** Les femmes enceintes, que leur grossesse soit confirmée ou non, devraient consulter un médecin avant d'utiliser une cuve de relaxation.

**AVERTISSEMENT:** Pour éviter des blessures, user de prudence en entrant dans une cuve de relaxation et en sortant.

**AVERTISSEMENT:** Ne pas utiliser une cuve de relaxation immédiatement après un exercice fatigant.

**ATTENTION:** La teneur de l'eau en matières dissoutes doit être conforme aux directives du fabricant.

## PERSONAL SAFETY

**WARNING:** Risk of Fatal Hyperthermia. Hyperthermia occurs when the internal temperature of the body reaches a level several degrees above the normal body temperature of 98.6°F (37°C). The symptoms of Hyperthermia include dizziness, lethargy, drowsiness, and fainting. The effects of Hyperthermia can also include:

- Unawareness of impending hazard and failure to perceive heat
- Failure to recognize the need to exit the spa
- Physical inability to exit the spa; unconsciousness and danger of drowning
- Fetal damage in pregnant women
- **WARNING:** The use of alcohol, drugs, and/or medication can greatly increase the risk of fatal Hyperthermia

Other booklets about spa safety are: “Children Aren’t Waterproof,” “Pool and Spa Emergency Procedures for Infants and Children,” “Layers of Protection” and “The Sensible Way to Enjoy Your Spa” published by Association of Pool & Spa Professionals.

**WARNING:** Risk of Fatal Hypothermia. Hypothermia occurs when the internal temperature of the body reaches a level several degrees below the normal body temperature of 98.6°F (37°C). The symptoms of Hypothermia include but are not limited to shivering, slurred speech or mumbling, slow, shallow breathing, weak pulse, clumsiness, drowsiness, confusion, unconsciousness, and bright red cold skin (in infants). The effects of Hypothermia include failure of the nervous system, respiratory system and heart and can also include:

- Unawareness of impending hazard and failure to perceive heat
- Failure to recognize the need to exit the spa; unawareness of impending hazard
- Fetal damage in pregnant women; physical inability to exit the spa and unconsciousness and danger of drowning
- **WARNING:** The use of alcohol, drugs, and/or medication can greatly increase the risk of fatal Hypothermia

People taking medications which induce drowsiness such as tranquilizers, antihistamines, or anticoagulants should not use the spa. Pregnant women and persons with a medical history of heart disease, diabetes, or high blood pressure should consult a physician before using the spa.

## PERSONAL SAFETY DOS:

- Be sure your spa is connected to the power supply correctly only use a licensed electrical contractor.
- Shut off power supply (unplug 120V models) before draining the spa or servicing the electrical components.
- Test the Ground Fault Circuit Interrupter (GFCI) monthly.
- Always test the water temperature with an accurate thermometer before entering the spa to be sure that it's a safe temperature.

- Do not use the spa if water temperature is outside of set temperature. Remember that wet surfaces can be very slippery. Take care when entering and exiting the spa.
- Lock the cover when the spa is not in use, whether it is empty or full of water.
- Keep the water clean and sanitized with correct chemical care.
- Turn on the jets when adding ANY chemicals to the spa water.
- Clean the filter cartridge(s) monthly to remove debris and mineral buildup which affects the performance of the hydrotherapy jets, limits the flow, or trips the high limit thermostat which will turn off the entire spa.

**PERSONAL SAFETY DO NOTs:**

- Don't use the spa with the equipment compartment door removed.
- Don't use the spa for more than 10 minutes at water temperatures in excess of 102°F (39°C).
- Don't allow the jet pump(s) to operate for an extended period of time with the cover in place. Extended pump operation causes a slow heat buildup due to water friction. The spa equipment controls are equipped with a built-in safety timer that automatically shuts off the jet pump(s) after 15 minutes of continuous operation should it have been left on inadvertently.
- Don't operate the spa at any time with the filter cartridges removed.
- Don't lift or drag the cover by using the tie-down straps; always lift and carry by using the external handles.
- Don't store chemicals in the spa's equipment compartment.
- Don't hesitate to call your authorized dealer to ask any questions or maintenance concerns.
  
- For your portable spa to function properly and safely, it must be located on a hard, flat, level surface. Inground spas require special installation techniques and should be planned in conjunction with your authorized Celebrity Hot Tubs dealer. Improper installation

## INSTALLATION INSTRUCTIONS LOCATION

can result in structural damage to the spa and the voiding of your spa warranty. Items to discuss with your dealer include Local construction codes, electrical service requirements, serviceability of equipment present underground obstructions such as gas, water, and telephone lines, safety measures such as fences and locks, and visibility of the spa installation from the home, street, and neighbors.

sensors may result.

- Do not shim your spa. If your pad is not level, you must pour a top cap: contact a professional.
- Allow for sufficient water drainage around the spa to help preserve the equipment and support structure. This includes indoor installations.
- A filled spa with users be substantial. Seek guidance from a qualified contractor or engineer before placing, connecting, and using the unit.
- Locate the equipment compartment where it will be accessible. Your spa **MUST** be installed to permit access for servicing the equipment above and/or below any decks or floors. Access is essential and must allow adequate room for service. To facilitate repairs, Celebrity Hot Tubs or its agent may require access to spa equipment. It is your responsibility to provide unencumbered access. See spa diagrams for location of power supply.
- Leave access to the circuit breakers in the sub panel (240V models) or to the interrupter switch (GFCI, 120V models) at the end of the power cord. Be sure the spa is level and in the final position **BEFORE** filling with water. Check for power cords, tools, and hoses that may be caught underneath the spa. Do not apply power to the spa before it is completely filled with water. Damage to the pumps, heater and sensors may result.

Spa surface temperatures can reach in excess of 180°F (82°C) if left exposed to the sun. Significant damage can occur if this is allowed to happen, including warping and blistering of the surface. Damage that occurs as a result of this exposure is not covered under the warranty.

**CAUTION:** Never try to move a spa that has not been fully drained. Doing so could result in damage to the spa and physical injury to the mover. Cracks in the spa

**INSTALLATION INSTRUCTIONS**

surface, exterior siding or base due to improper transport or support of the spa are not covered under the warranty.

**OUTDOOR AND PATIO INSTALLATION**

To install the spa outdoors, we recommend a reinforced concrete pad at least four inches thick. The reinforcing material should be attached to a #8 AWG bonding wire (#6 AWG in Canada) per national and local electrical code.

If you place the spa on the ground, even temporarily, place the spa empty of water on concrete pavers under the entire bottom of the spa. The concrete pavers should be at least two inches thick and level across the entire surface. The spa will inevitably settle and not remain level on this surface, thus it's important to get the spa onto a solid foundation as soon as possible.

**INSTRUCTIONS FOR PREFABRICATED SPA PADS**

If you are using a prefabricated spa pad for a foundation, please use the following guidelines:

1. Designate the area where the spa is to be installed. Please make sure the ground is flat and level.
2. Using 2"x 6" (51mm - 152mm) weather resistant lumber and 3" (76mm) outdoor deck screws, build a frame large enough for the prefabricated spa pad to fit inside with minimum 1" (25mm) clearance on all sides.
3. Install the frame in the area that has been leveled.
4. Using crushed gravel, fill the frame to the top.
5. Lay a straight piece of lumber across the frame and level any high spots in the gravel by pushing the straight lumber across the frame. Fill in any low areas with more gravel and re-level using the straight piece of lumber.
6. Compact the gravel to make the surface hard and flat. You may need to add more gravel to bring the level back up to the top of the frame. If so, please relevel and recompact until you have a hard, flat level surface that is even with the top of the frame.
7. Place the prefabricated spa pad on top of the gravel. Please be careful not to disturb the hard, flat, level surface.
8. Please make sure no portion of the spa pad is sitting outside or on top of the framing.
9. Place the spa on top of the pad and fill the spa with water.

**DECK INSTALLATION**

Be sure the deck can support the weight of your filled spa by checking the deck's maximum capacity. Consult a qualified building contractor or structural engineer to determine adequacy of the deck to support the specific product you have purchased.

## INSTALLATION INSTRUCTIONS LOCATION

### INDOOR INSTALLATION

There are special requirements if you place your spa indoors. Flooring material must provide adequate traction when wet. Proper drainage is essential to prevent water puddling. For spa/hot tubs installed indoors, care should be taken to ensure adequate ventilation for the indoor space, to avoid undesired build of humidity due to spa water. For additional information on ventilation/humidity guidelines see the ASHRAE Handbook, HVAC Applications, I-P Edition, 4.5, 4.6, and 4.7.) Please see your contractor for details.

**WARNING:** This appliance is not intended for use by young children or unhealthy people without supervision.

Included with the spa is a warning sign to inform users and guests of the risks involved with using a spa. This sign is suitable for indoor and outdoor use. It should be placed in a visually noticeable location adjacent to the spa. For free additional or replacement copies, contact your authorized Marquis Hot Tub Dealer.

 <b>WARNING</b> <sup>a</sup>
<b>REDUCE THE RISK OF ELECTROCUTION</b> <sup>b</sup> 1. Never place an electric appliance within 5 feet of spa. <sup>c</sup>
<b>REDUCE THE RISK OF CHILD DROWNING</b> <sup>b</sup> 1. Supervise children at all times. <sup>c</sup> 2. Attach spa cover after each use. <sup>c</sup>
<b>REDUCE THE RISK OF OVERHEATING and EFFECTS OF COLD WATER IMMERSION</b> <sup>b</sup> 1. Check with a doctor before use if pregnant, diabetic, in poor health, or under medical care. <sup>c</sup> 2. Exit immediately if uncomfortable, dizzy, shivering, or sleepy. Spa heat can cause hyperthermia and unconsciousness. Sudden or Prolonged exposure to cold water immersion can cause hypothermia and related injuries. <sup>c</sup> 3. Spa heat or immersion in cold water in conjunction with alcohol, drugs, or medication can cause unconsciousness. <sup>c</sup>
<b>WHEN PREGNANT</b> <sup>b</sup> , soaking in hot/cold water for long periods can harm your fetus. Measure water temperature before entering. <sup>c</sup> 1. Do not enter spa if water is hotter than 100° F (38° C). <sup>c</sup> 2. Do not stay in spa for longer than 10 minutes. <sup>c</sup>

**INSTALLATION INSTRUCTIONS****INSTALLATION INSTRUCTIONS**

**Shut-off valve  
in open  
position**

**SHUT-OFF VALVES**

Your spa is equipped with shut-off valves (see EQUIPMENT DIAGRAM) that shut off the water flow to the equipment system for authorized Celebrity Hot Tubs dealer service. At times, a new spa or one that has recently been serviced, may have the shut-off valves partially closed which can restrict the water flow and hinder jet performance. Be sure the valves are fully open.

Shut-off valve in open position

**FREEZE PROTECTION**

When a freeze condition is detected (which occurs when the temperature in the heater housing drops to 55°F, (13°C) the jet pump(s) is automatically activated. In areas with extremely cold winter conditions, your spa should be fine as long as it is left running at normal operating temperatures. For extra protection see your dealer for an optional freeze sensor. If you plan to turn the spa off, follow the instructions in this manual (see SUSPENDED USE OR WINTERIZING YOUR SPA).

**OVERHEATING**

Your Celebrity Hot Tub is equipped with the ConstantClean™ Filtration system and it features one filter, 35 sq ft cartridge.

**Removal and Installation:** Turn off the unit prior to changing and replacing the filter cartridge. Remove cap or cover by lifting straight up while holding the perimeter with your hands.

**FILTER CARTRIDGES**

Your portable spa is equipped with the ConstantClean™ Filtration system. It features one filter, 35 sq ft in Celebrity.

**Removal and Installation**

Remove cap or cover by lifting straight up while holding the perimeter with your hands.

To remove the filter, find the raised bar on the top of the filter and turn counterclockwise.

To reinstall, slowly insert the filter, threads down, into the skimmer. Using the raised bar on the top of the filter, slowly turn clockwise until it's snug. Do not overtighten as this may strip or break the threads of the filter cartridge.

Reinstall cap or cover on skimmer top and turn until back on.

**INSTALLATION INSTRUCTIONS LOCATION**

**Safety guard of suction fitting must remain in place.**

**SUCTION GUARDS**

The suction guard(s) in the footwell of your spa is an opening through which the jet pump(s) draws water. The suction fittings have an integrated vacuum release built into them. In the event that a suction fitting gets blocked, air will be induced causing the pump to cavitate and the water flow interrupted. Once the blockage is removed, normal operation will resume. Suction fittings are equipped with a safety guard.

Suction through the fittings can be strong. The safety guard(s) must remain in place and undamaged. A fitting with a damaged guard(s) can be dangerous, especially to small children or people with long hair.

Should any part of the body become drawn to a fitting, turn the jet pump(s) off immediately. Long hair should be restrained. Never allow long hair to float freely in the spa. Replace any missing or damaged suction guard(s).

**NOTE:** It is normal for the flow rates of the suction fittings to vary from strong to barely noticeable

**STARTING YOUR SPA**

Improperly wired spas are beyond Celebrity Hot Tubs control and are not covered under the warranty. Other items beyond Celebrity Hot Tubs control include, but are not limited to, damage resulting from: improper connections; accidents; failure to follow procedures and instructions defined in the Celebrity Hot Tubs printed instructions; cleaning agents; and natural occurrences including but not limited to rodent or insect infestation, mold, lightning and other acts of nature.

**ELECTRICAL REQUIREMENTS**

It is the responsibility of the spa owner to ensure that all electrical connections are made by a qualified electrician in accordance with all national, state, and local electrical codes in effect at the time of installation. Fuses are covered to be free of defect at time of installation only.

**240 Volt**

All connections must be made in accordance with the wiring diagram found on the inside of the control box cover. Connections must be made with copper conductors only – *do NOT use aluminum wire*. All conductors, circuit breakers, and fuses and the GFCI must be sized in accordance to the total amperage load as specified below. Wiring diagram is located on the back of the cover on the equipment enclosure.

Improperly wired spas can cause irreversible damage resulting in a blown fuse and melted terminal block, and to other electrical components. Also, damage caused to components or equipment caused by high or low voltage, brown outs or electric surges is not covered under warranty.

Permanently connected (Hard wired).

Rated 240V, 60Hz, 50A, three wires (6 copper) plus ground (#8 copper (8.42mm<sup>2</sup>)), [4 wires total].

Circuit breaker or fuse size: 50A.

A disconnecting means must be installed within sight of the equipment and at least 5 feet (1.52m) from the inside walls of the spa. Connect only to a circuit protected by a Class A ground Fault Circuit Interrupter (GFCI).

Wiring Diagram

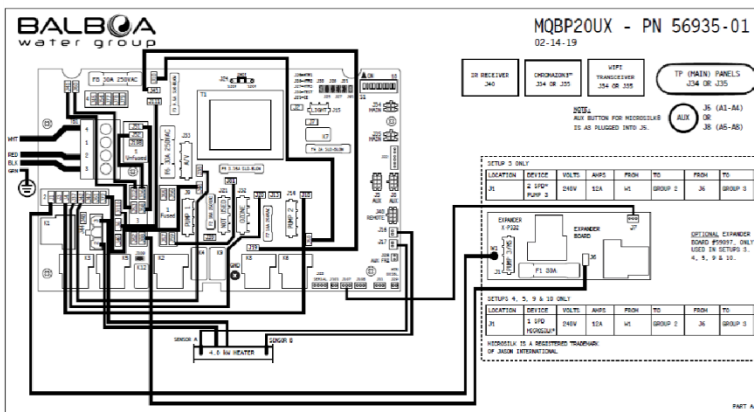

**120 Volt**

120 Volt spas shall be plugged into a properly grounded, grounding type 20 Amp receptacle on a dedicated circuit. A dedicated circuit is a circuit with no other components that consume power, such as lights, televisions, radios, computers, or other electronic devices. These could cause your spa to malfunction by any of the following: unusual text on the control panel, slow heating, poor jet action, tripping house breaker, or blown fuses. Failure to follow these instructions could lead to premature failure of spa components that would not be covered under the warranty. The dedicated circuit shall meet the following specifications:

Rated 120V, 60Hz, 15A (2 wires plus ground)

Circuit breaker or fuse size: 15A

The receptacle must be at least 5 feet (1.52 m) from the spa.

The 15-foot GFCI power cord provided with the spa must be plugged directly into the receptacle. Do NOT use an extension cord or any other adaptor. Actual exposed length of cord will vary by model but will never be less than 12 feet.

**Convert 120 Volt to 240 Volt**

120 Volt spas may be converted to operate on 240V, 50A. Wiring must be performed by a licensed electrician in accordance with the NEC and any local or regional electric codes.

Disconnect the power: Unplug GFCI cord from wall receptacle. Disconnect cord end from terminal block and ground bar inside equipment box.

Move white jumpers on J24 to connect the two middle pins only.

Failure to do this will result in a blown transformer.

For 50-amp operation Move dip switch #2 up to the on position. This will allow the heater to operate on pump 1 high speed. Install 240V power as indicated on the 240V section.

Remove the jumper wire connecting J79 to J61 and discard.

Reconnect the spa with 240V power to approved GFCI and exterior mounted disconnect.

Improperly wired spas are beyond Marquis Corp. control and are not covered under the warranty. Other items beyond Marquis Corp. control include, but are not limited to, damage resulting from: improper connections; accidents; failure to follow procedures and instructions defined in the Marquis® printed instructions; cleaning agents; and natural occurrences including but not limited to rodent or insect infestation, mold, lightning and other acts of nature.

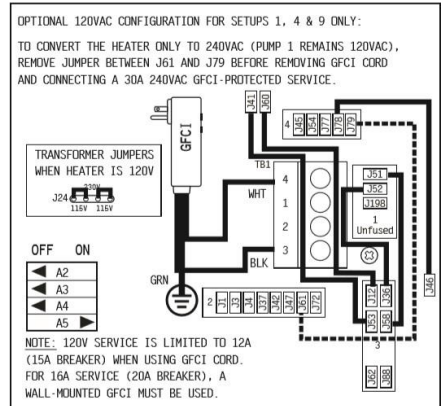

## STARTUP PROCEDURE

Your spa is equipped with solid state controls specific to your spa model. (See SPA CONTROL OPERATION for your specific spa model.)

To start your spa, you need spa test strips. It is important to follow each of these steps when starting your spa. Once you have completed the following steps, see SPA CARE AND ENJOYMENT GUIDE for proper water treatment.

**NOTE:** Your spa has been filled and test run at the factory. The first time your spa is filled with water, some discoloration from residual test water may appear. This will disappear when the spa is completely filled and the filtration system is functioning.

**WARNING:** Spa must be completely filled with water 2/3 the way up the filter before turning on power.

Test the water for the proper chemical balance and adjust as necessary. Marquis Water Care products are recommended. (See WATER TREATMENT.) PROPER CHEMICAL BALANCE IS IMPORTANT for your safety and the longevity of your spa.

In the event of relocating your spa, it is imperative to follow the instructions in the owner's manual. These instructions must remain with the spa. Damage caused by relocating spa is not covered under warranty.

## THERAPY PUMP(S)

Allow the spa to circulate on high-speed (see SPA CONTROL OPERATION) for four to five minutes to discharge air from the plumbing system. Do not expect hot water immediately from the jets; the heater will take several hours to heat the water.

Startup procedure for all models

1. Place spa on a hard, flat, level surface. Make sure the
2. Power supply is off.
3. Make sure the suction guard(s) in the footwell are in place and undamaged.
4. Open the equipment door. Tighten all fittings and open all shut-off valves. Tighten the pump plug(s) from the pump(s). (See EQUIPMENT DIAGRAM.)



**Vent air by  
slightly  
opening  
pumps  
unions.**

**NOTE:** Keep the drain valve closed at all times except when draining the spa (do not rely on the cap to stop the flow of water). Not doing so could result in damage to the drain valve due to freezing water.

1. Install filter cartridges. (See INSTALLATION INSTRUCTIONS, Filter Cartridges, page 10.)

## STARTING YOUR SPA

2. Fill the spa with water two thirds of the way up the skimmer openings. The use of a *Fill Filter* is recommended, especially in areas with high mineral content in the water.
3. Turn the power on.
4. Your spa is now in “pump priming” mode and a “RUN PMPS PUR AIR” message displays in the LCD window of the control panel. While in this mode the spa appears idle, which lasts approximately four to five minutes if not exited manually. To exit manually, press the TEMP pad.
5. Allow the spa to circulate on high-speed (see SPA CONTROL OPERATION) for four to five minutes to discharge air from the plumbing system. Do not expect hot water immediately from the jets; the heater will take several hours to heat the water.
6. At this time the spa should have water flowing from the jets. If the pump has not primed and the water is not flowing from the jets after two minutes TURN OFF POWER TO THE SPA and vent air from the pumps by slightly opening the pump unions. After turning the power on again, the spa initiates a new priming mode. Repeat steps above.
7. The system requires approximately two minutes of water flow to determine the water temperature. After two minutes of water flow, the temperature is displayed as actual water temperature. After you have manually exited the priming mode (or allowed the spa to automatically exit) the LCD window momentarily displays 100°F (38°C) and then the display switches to - - °F.
8. The factory default setting for water temperature is 100°F (38°C). Use the TEMP pad on the control panel to set the water temperature to the desired level. (See SPA CONTROL OPERATION.) It takes up to 24 hours to heat the water to desired temperature depending on the water temperature and voltage of your spa.
9. If water is not coming out of the jets, check to make sure the adjustable jets are open. Simply turn the jet face to open or close the jets.
10. SPA COVER
11. When the spa is not in use, the cover should be kept on the spa to retain the water's heat and to keep out dirt, leaves, etc.
12. For your safety and convenience, the cover is equipped with adjustable straps, safety locks, and handles. Use the exterior handles to remove and replace your cover. Never attempt to open or remove the cover by grasping or pulling on the cover skirting or cover lock straps as the skirting will tear.
13. We suggest you use the safety locks to help keep out unintended users, prevent covers from being blown off in windy conditions and to maximize heat retention/energy efficiency. The cover and retractable cover system are not recommended for use in wind conditions reaching above 25 miles per hour. If your spa is located in an area susceptible to high winds, additional Wind Straps may be necessary to minimize cover damage.

## STARTING YOUR SPA

14. NOTE: The cover is designed for optimum protection of the spa shell. Using an aftermarket cover will not provide the same protection and will void the shell warranty.
15. Open the spa cover:
16. Unfasten all cover lock straps.
17. Place one hand under the cover skirting, between the spa and cover, to break the cover's vacuum seal. Do not use cover handles to break vacuum seal.
18. Fold the front half of the cover over onto the back half.
19. NOTE: Unlock and release all cover locks before attempting to open cover. Damage caused by attempting to open the cover while locked or by wind is not covered under warranty. Do not walk, stand, climb, or sit on the vinyl cover or retractable cover system. Do not use hard, sharp, or metal objects, such as a windshield scraper, to remove ice. Such objects can cut, mar, or puncture the cover's vinyl surface.
20. Close the spa cover:
21. Slide folded cover onto one half of spa.
22. Unfold the cover by lifting the handle located on the top (front) half of the cover. Allow the unfolded half to gently fall down onto the spa.
23. Secure the cover lock straps to the spa and lock them.
24. NOTE: When opening a cover with a cover removal mechanism, use one of the manufacturer's recommended methods. Do not attempt to open the cover in any other way. Damage caused by improper opening or closing of the cover is not covered under the warranty.
25. Fading, staining, torn stitching of the spa cover and broken foam cores are not covered under the warranty for any reason. Spa covers do not qualify for labor coverage under the warranty. These parts can be purchased or exchanged under warranty at your authorized Celebrity Hot Tubs dealer.

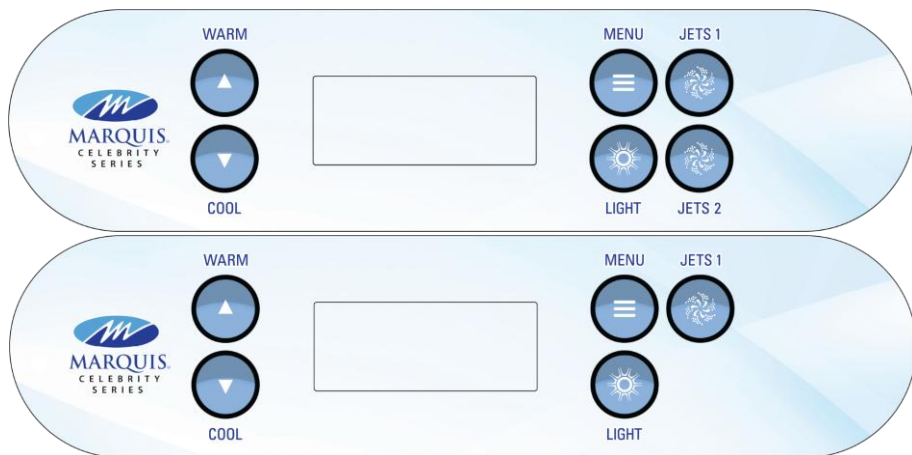
**OPERATING THE ELECTRONIC CONTROLS**

**Celebrity Control Panel**
**Jets**

One pump model: If the pump is off, press **JETS 1** button to turn on pump 1 to low speed. Press a second time to turn the pump on to high speed. Press the third time to turn the pump off.

For two pump models press: the **JETS 2** button once for high speed. The high speed of pump 1 will run for 15 minutes and then switch to low speed. Once at a low speed the pump will run for 15 minutes. To restart the pump, press the **JETS 1** or **JETS 2** button. The yellow LED indicator under the LCD display will illuminate anytime the pump is running.

NOTE: If the system is in a filter or heating cycle, low speed will continue to run.

**Zone Control (when equipped)**

Depending on the model purchased, the unit may be equipped with a Turn the 2-Way Valve to divert the jet action to another zone in the hot tub. Refer to the Zone diagrams for location of the 2-Way Valves and what jets are controlled when selected.

**Adjusting temperature (factory default 100° F)**

To adjust the temperature of the water, press the WARM button. The first press of the button will display the set temperature and begin to flash. Continue to press or hold the WARM button to reach the desired set temperature. Once the display stops blinking the new temperature setting will be set. The factory default setting is 100° F (38° C). The minimum temperature that can be set is 60° F (16° C) and the maximum temperature that can be set is 104° F (40° C). The display always shows actual water temperature.

### **Light**

Press the **LIGHT** button to turn the interior spa lights on and off. If left on the lights will run for 60 minutes and then turn off automatically.

### **USER PROGRAMMING**

The following features allow for additional control and setting of the onboard electronics. In most cases the factory default settings are adequate for normal use and operation. To access any of the following features press **TEMP** and then **Light**: then scroll through the features by continuing to press the **LIGHT** button. You exit the programming mode at any time by continuing to press the **LIGHT** button until you arrive back at the temperature display or by simply pausing for 30 seconds.

**Filtration Cycles (Factory default is 1 hour two times per day)**

Your hot tub will begin the first of two filtration cycles 5 minutes after it has been powered up. The second filtration cycle will start 12 hours later. To change the time when the filtration cycles run, power down the spa for 1 minute and then turn the power back on at the point in time you want the spa to filter. For example, if you want the spa to filter at 3 PM and 3 AM, power the hot tub down at 2:55 PM or 2:55 AM. This will reset when the hot tub will run the filter cycles. In the event that the power to the hot tub is interrupted, you will need to repeat this procedure. Programming how long the spa will filter.

The electronic controls will allow you to change the length of time the hot tub will filter the water. This can be useful if your usage patterns vary from light to heavy and/or you need more or less filtration time to aid in maintaining water clarity. To adjust the filtration times, press the listed buttons in the following sequence. Button presses must occur within 30 seconds of each other.

#### **To Program:**

Press the **WARM** button followed by the **LIGHT** button to enter the programming mode.

Press the **WARM** button to make a change to the desired length of time. (each press changes the time in 1 hour increments).

Press the **LIGHT** button to set your selection and exit the filtration time option. If you do not do this the choice will not be saved.

**Mode (Ready mode is factory default recommended)**

This feature can be used for periods when you will be gone for an extended amount of time and don't want the hot tub running on a continual basis. Running the unit in "Ready" mode will ensure the spa is at full temperature and ready for use at any time. Running the unit in "Rest" mode will only allow the spa to heat during a scheduled filtration cycle. To access and change the mode, press the listed buttons in the following sequence. Button presses must occur within 30 seconds of each other. Ready and Rest indicators are shown under the temperature in the display. When in Rest mode the panel may display "**RUN PMPS OR WARM**".

#### **To Program:**

**SPA CONTROL OPERATION**

Press the **WARM** button followed by the LIGHT button to enter the programming mode.

Press the **LIGHT** button again to enter the "Mode" option.

Press the **WARM** button to toggle between "Ready" and "Rest" options.

Press the **LIGHT** button to set your selection and exit the filtration time option. If you do not do this the choice will not be saved.

**MOTOWN AUDIO SYSTEM (Optional)**

Please refer to the manufacturer's owner's manual for features, operation, and troubleshooting.

**NOTE:** Avoid water splashing on the stereo face. Moisture can damage internal components. Water intrusion into stereo is not covered under warranty. See manufacturer's owner's manual for coverage information. Consult your Limited Warranty for more information about coverage.

**CAUTION - Risk of Electric Shock.** Replace components only with identical components.

Do not operate the audio controls while inside the spa.

**WARNING – Prevent Electrocution.** Do not connect any auxiliary components (for example, cable, additional speakers, headphones, additional audio/video components, etc.) to the system, except as provided by the following: The 3.5 mm auxiliary jack is designed for input only from devices such as an MP3 player operating at 4.5 V or less.

These units are not provided with an outdoor antenna; it should be installed in accordance with Article 810 of the National Electrical Code, ANSI/NFPA 70.

Do not service this product yourself as opening or removing covers may expose you to dangerous voltage or other risk of injury. Refer all servicing to qualified service personnel.

If the power supply connections or power supply cord(s) are damaged; if water is entering any electrical equipment compartment area; or if there are signs of other potential damage to the unit, turn off the unit and refer servicing to qualified service personnel.

This unit should be subjected to periodic routine maintenance (i.e. once every three months) to make sure that the unit is operating properly.



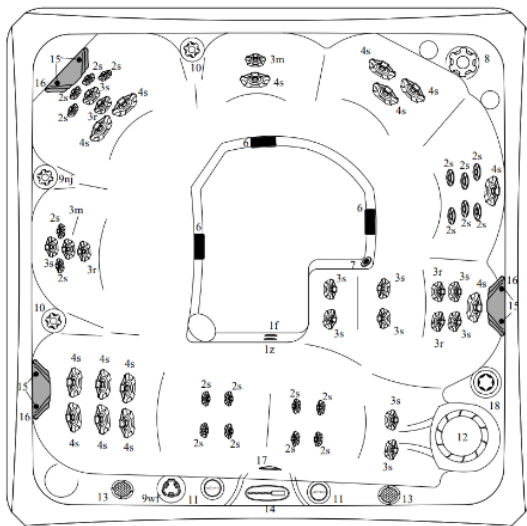

**Audio Expansion Port (Optional)**

The built-in audio expansion port allows you to connect optional accessories. Use the supplied 3.5 mm cord to attach MP3 player. **NOTE:** The 3.5 mm auxiliary jack is designed for input only from devices such as an MP3 player operating at 4.5V or less.

**CELEBRITY HOT TUBS MODELS DIAGRAMS**
**THE WOODSTOCK™**

#	Component Identification	Qty.
1f	In-line Sanitation Fitting (optional)	1
1z	Ozone Wall Fitting	1
2s	200 Series Jets Straight	20
3s	300 Series Jets Straight	10
3r	300 Series Jets Rotator	4
3m	300 Series Jets Multi-port	2
4s	400 Series Jets Straight	14
6	Suction Fittings	3
7	Floor Drain	1
8	2-Way Valve	1
9wf	Waterfall Valve	1
9nj	Neck Jet Valve	1
10	Air Control Valves	2
11	Waterfall	2
12	Skimmer	1
13	Stereo Speakers (optional)	2
14	Control Panel	1
15	Headrest Buttons	6
16	Headrests	3
17	LED Light	1
18	In-line Housing (optional)	1
<b>Physical Specifications</b>		
Dimensions	US/CA	INTL
	90" x 90"	229 x 229 cm
Height	36"	91 cm
Seating Capacity/Positions	7/7	7/7
Weight Dry	780	354 kg
Weight Full	4621	2096 kg
Water Capacity	460	1741 l
Total Therapy Jets	50	50

## WOODSTOCK™ ZONES

-  PUMP 1 ZONE 1
-  PUMP 1 ZONE 2
-  PUMP 1 NECK JETS
-  PUMP 2 ZONE 1

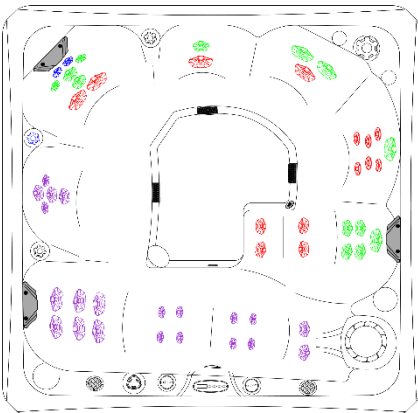
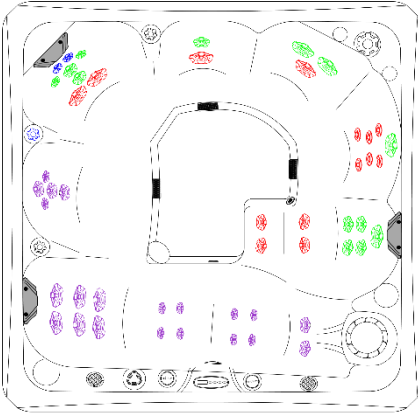
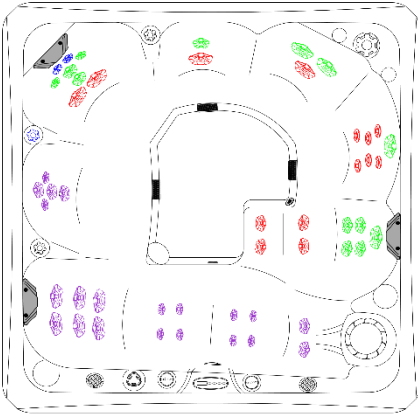

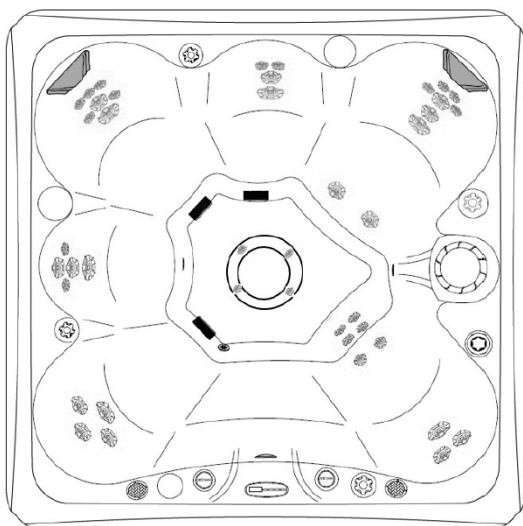

## THE VEGAS™

#	Component Identification	Qty.		
1f	In-line Sanitation Fitting (optional)	1		
1z	Ozone Wall Fitting	1		
2s	200 Series Jets Straight	21		
3s	300 Series Jets Straight	7		
3r	300 Series Jets Rotator	4		
3m	300 Series Jets Multi-port	2		
4s	400 Series Jets Straight	6		
6	Suction Fittings	3		
7	Floor Drain	1		
9wf	Waterfall Valve	1		
9nj	Neck Jet Valve	1		
10	Air Control Valves	2		
11	Waterfall	2		
12	Skimmer	1		
13	Stereo Speakers (optional)	2		
14	Control Panel	1		
15	Headrest Buttons	4		
16	Headrests	2		
17	LED Lights	1		
18	In-Line Housing (optional)	1		
Physical Specifications		US/CA	INTL	
Dimensions		84" x 84"	213 X 213 cm	
Height		36"	91 cm	
Seating Capacity/Positions		7/7	7/7	
Weight Dry		700	318 kg	
Weight Full		3873	1757 kg	
Water Capacity		380	1438 l	
Total Therapy Jets		40	40	

## THE VEGAS™ ZONES

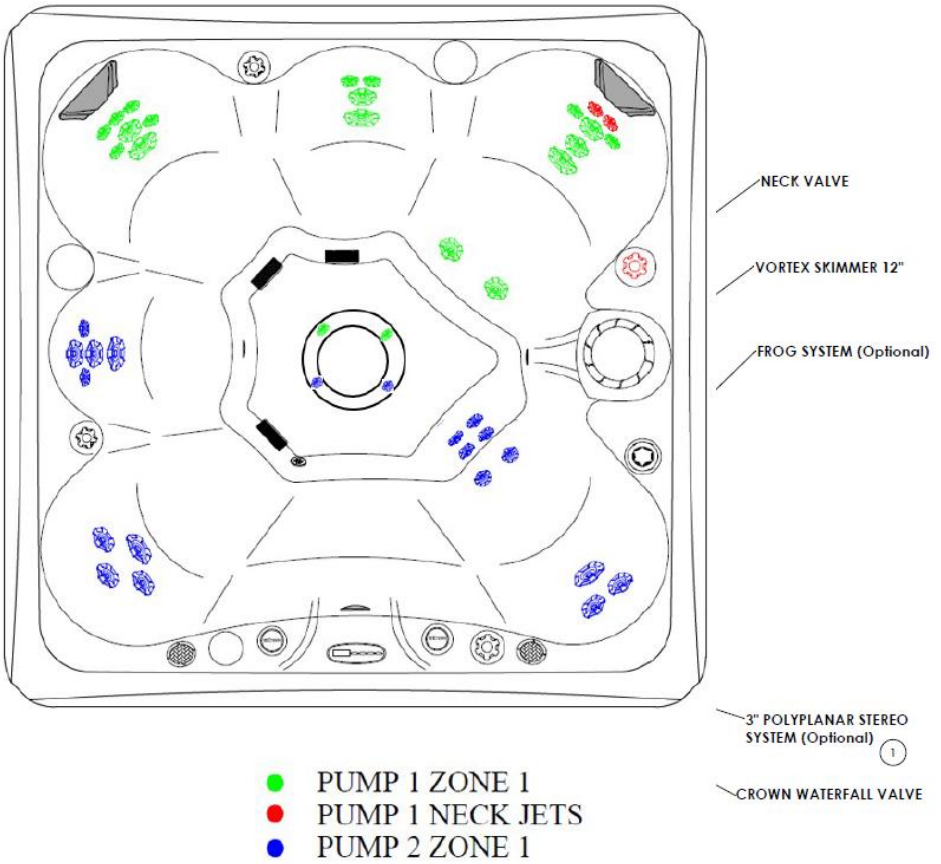

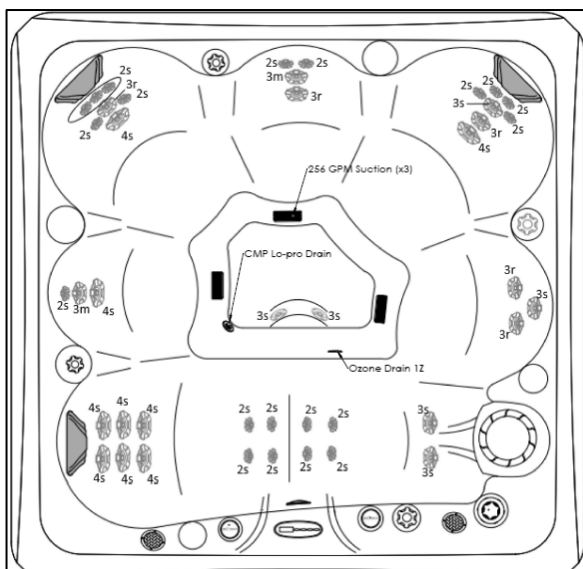
**THE HOLLYWOOD™**

#	Component Identification	Qty.
1f	In-line Sanitation Fitting (optional)	1
1z	Ozone Wall Fitting	1
2s	200 Series Jets Straight	20
3s	300 Series Jets Straight	4
3r	300 Series Jets Rotator	5
3m	300 Series Jets Multi-port	2
4s	400 Series Jets Straight	9
6	Suction Fittings	3
7	Floor Drain	1
9wf	Waterfall Valve	1
9nj	Neck Jet Valve	1
10	Air Control Valves	2
11	Waterfall	2
12	Skimmer	1
13	Stereo Speakers (optional)	2
14	Control Panel	1
15	Headrest Buttons	6
16	Headrests	3
17	LED Lights	1
18	In-line Sanitation Housing (optional)	1
<b>Physical Specifications</b>		
Dimensions	US 84" x 84"	INTL 213 x 213 cm
Height	36"	91 cm
Seating Capacity/Positions	6/6	6/6
Weight Dry	740	336 kg
Weight Full	3659	1660 kg
Water Capacity	350	1325 l
Total Therapy Jets	41	41

## THE HOLLYWOOD™ ZONES

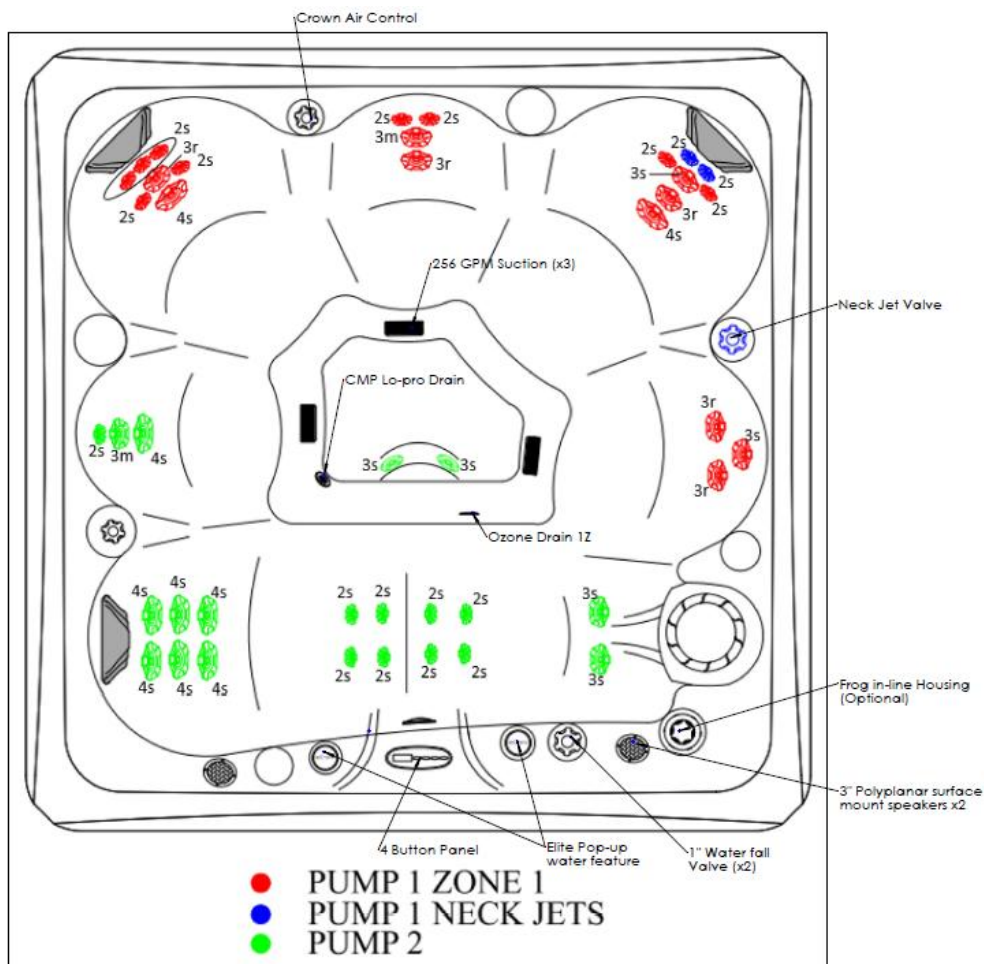



## THE BROADWAY™ ZONES

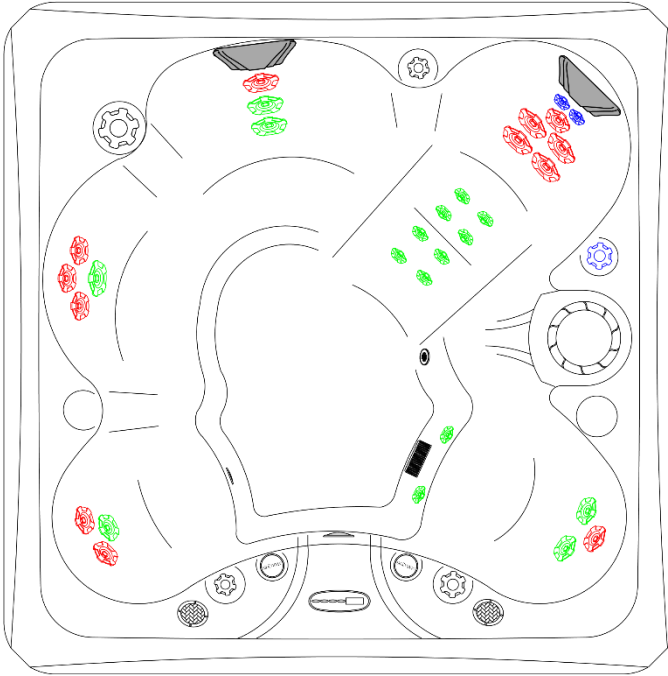

- PUMP 1 ZONE 1
- PUMP 1 NECK JETS
- PUMP 1 ZONE 2

**MONACO™**

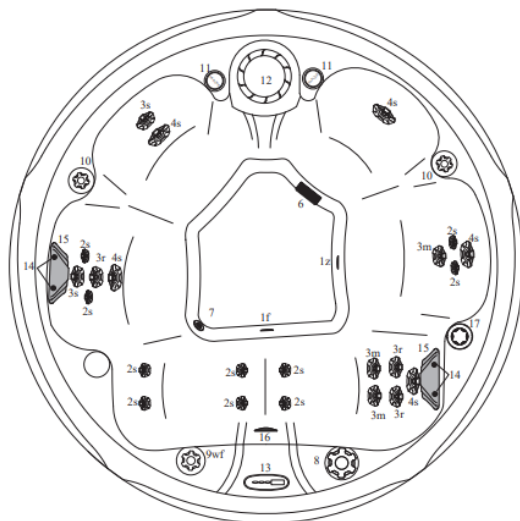

#	Component Identification	Qty.
1f	Frog Wall Fitting (optional)	1
1z	Ozone Wall Fitting	1
2s	200 Series Jets Straight	10
3s	300 Series Jets Straight	2
3r	300 Series Jets Rotator	3
3m	300 Series Jets Multi-port	3
4s	400 Series Jets Straight	5
4r	400 Series Jets Rotator	0
6	Suction Fittings	1
7	Floor Drain	1
8	2-Way Valve	1
9wf	Waterfall Valve	1
10	Air Control Valves	2
11	Waterfall	2
12	Skimmer	1
13	Control Panel	1
14	Headrest Buttons	4
15	Headrests	2
16	LED Light	1
17	In-Line Housing (optional)	1
<b>Physical Specifications</b>		
Dimensions	US/CA 80" x 80"	INTL 203 Dia.cm
Height	36"	91 cm
Seating Capacity/Positions	2/3	2/3
Weight Dry	500	227 kg
Weight Full	2590	1175 kg
Water Capacity	250	946 l
Total Therapy Jets	23	23

## THE MONACO™ ZONES

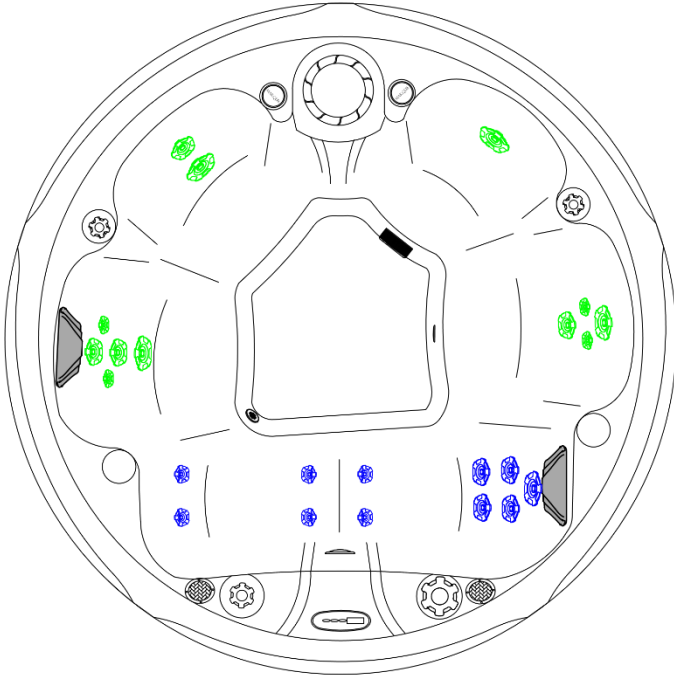

● PUMP 1 ZONE 1

● PUMP 1 ZONE 2

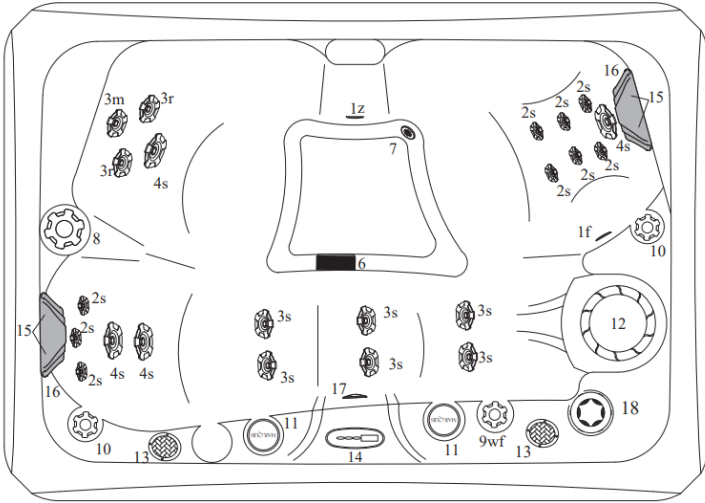
**CELEBRITY HOT TUBS EQUIPMENT  
 DIAGRAM**
**THE NASHVILLE™**

#	Component Identification	Qty.
1f	In-line Sanitation Fitting (optional)	1
1z	Ozone Wall Fitting	1
2s	200 Series Jets Straight	9
3s	300 Series Jets Straight	6
3r	300 Series Jets Rotator	2
3m	300 Series Jets Multi-port	1
4s	400 Series Jets Straight	4
6	Suction Fittings	1
7	Floor Drain	1
8	2-Way Valve	1
9wvf	Waterfall Valve	1
10	Air Control Valves	2
11	Waterfall	2
12	Skimmer	1
13	Stereo Speakers (optional)	2
14	Control Panel	1
15	Headrest Buttons	4
16	Headrests	2
17	LED Light	1
18	In-line Sanitation Housing (optional)	1
<b>Physical Specifications</b>		
Dimensions	US/CA	INTL
Dimensions	60" x 84"	152 x 213 cm
Height	29.5"	75 cm
Seating Capacity/Positions	2/3	2/3
Weight Dry	400	181 kg
Weight Full	2026	919 kg
Water Capacity	225	852 l
Total Therapy Jets	22	22

## THE NASHVILLE™ ZONES

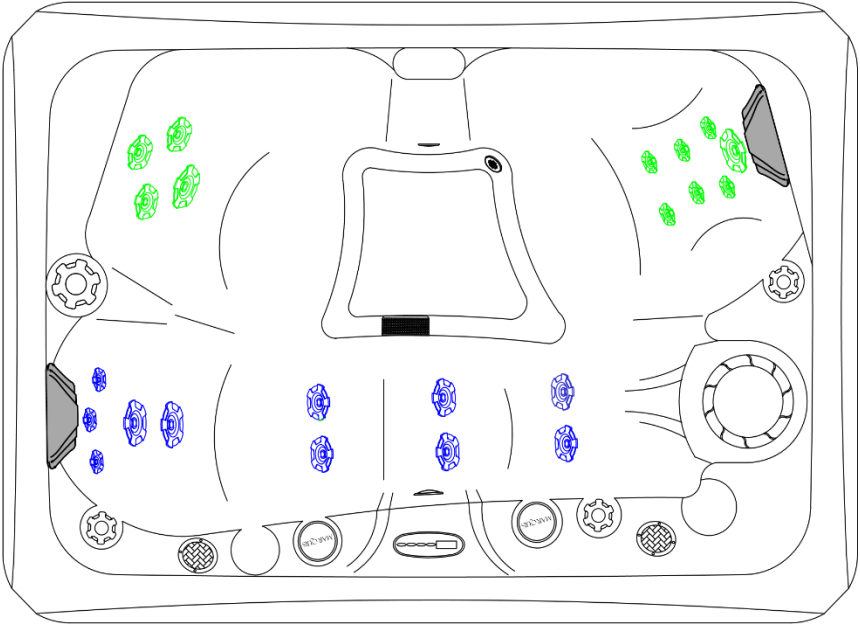

● PUMP 1 ZONE 1

● PUMP 1 ZONE 2

**CELEBRITY HOT TUBS EQUIPMENT  
 DIAGRAM**

**WOODSTOCK EQUIPMENT**

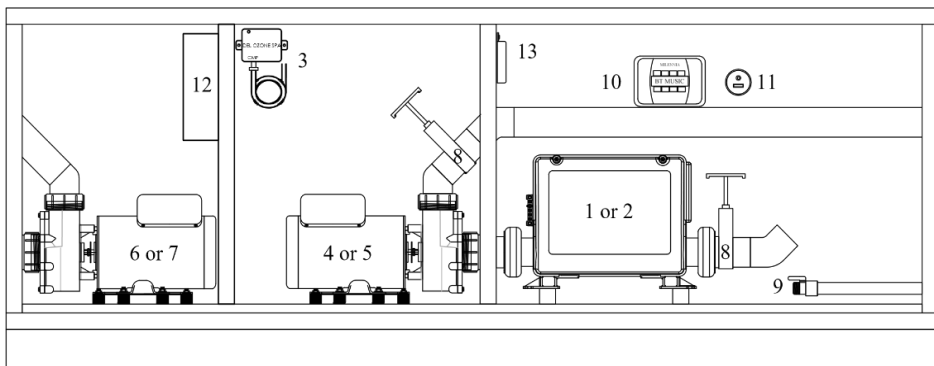

#	Component	Qty.
1	Control box and heater	1
3	Ozonator (optional)	1
4	Pump	1
5	Pump unions	4
6	Pump	1
8	Slice valves	2
9	Hose bib drain	1
10	Audio system (optional)	1
11	Audio expansion port (optional)	1
12	Stereo power supply (optional)	1
13	ControlMySpa Module (optional)	1

## VEGAS & HOLLYWOOD EQUIPMENT

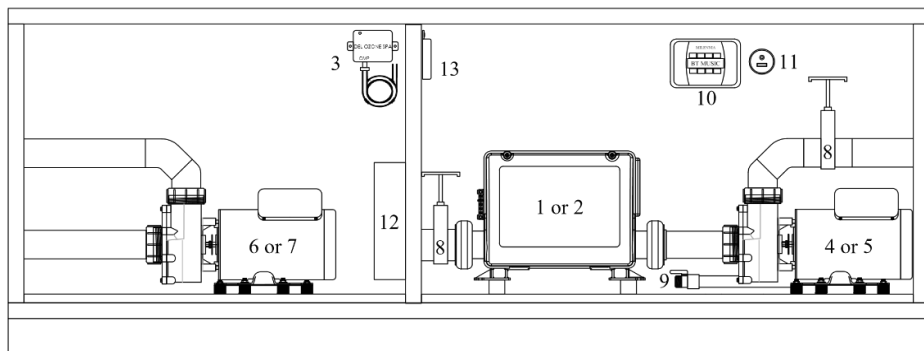

#	Component	Qty.
1	Control box and heater	1
3	Ozonator (optional)	1
4	Pumps	2
5	Pump unions	4
8	Slice valves	2
9	Hose bib drain	1
10	Audio system (optional)	1
11	Audio expansion port (optional)	1
12	Stereo power supply (optional)	1
13	ControlMySpa Module (optional)	1

**CELEBRITY HOT TUBS EQUIPMENT  
 DIAGRAM**

**BROADWAY EQUIPMENT**

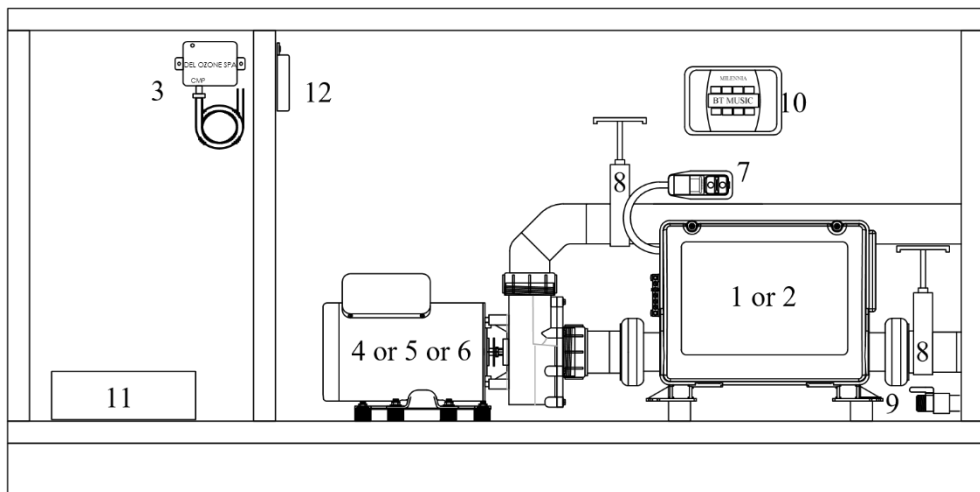

#	Component	Qty.
1	Control box and heater	1
3	Ozonator (optional)	1
4	Pump	1
5	Pump unions	2
7	GFCI (115V US/CA)	1
8	Slice valves	2
9	Hose bib drain	1
10	Audio system (optional)	1
11	Audio expansion port (optional)	1
12	Stereo power supply (optional)	1
13	ControlMySpa Module (optional)	1

## NASHVILLE EQUIPMENT

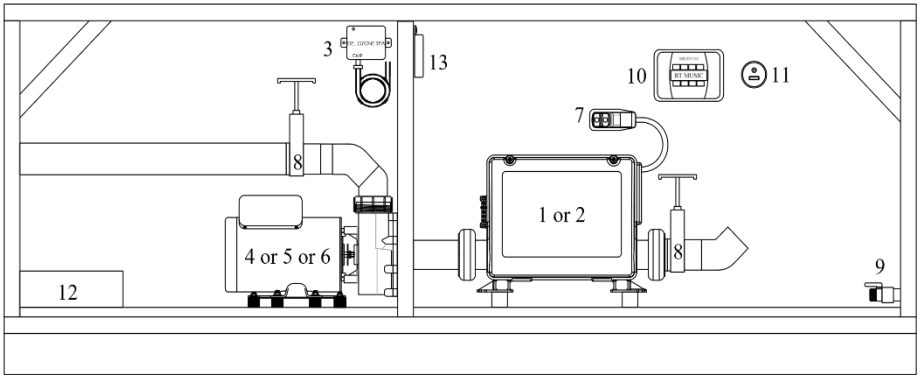

#	Component	Qty.
1	Control box and heater	1
3	Ozonator (optional)	1
4	Pump	1
5	Pump unions	2
7	GFCI (115V US/CA)	1
8	Slice valves	2
9	Hose bib drain	1
10	Audio system (optional)	1
11	Audio expansion port (optional)	1
12	Stereo power supply (optional)	1
13	ControlMySpa Module (optional)	1

**CELEBRITY HOT TUBS EQUIPMENT  
 DIAGRAM**

**MONACO EQUIPMENT**

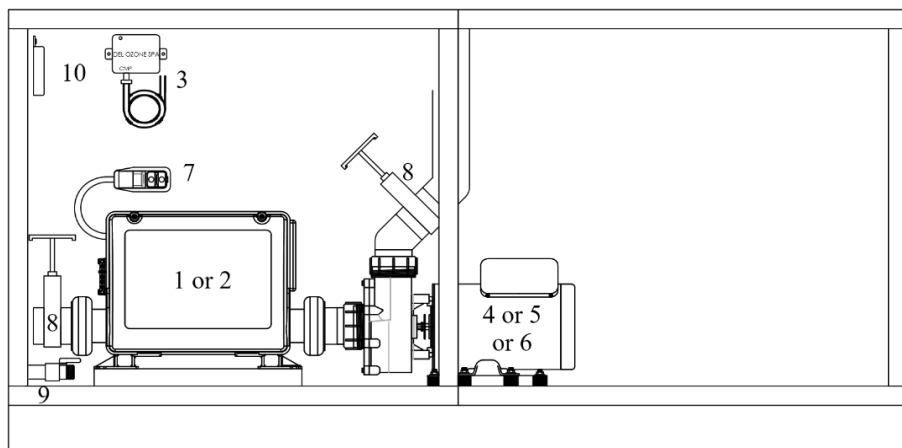

#	Component	Qty.
1	Control box and heater	1
3	Ozonator (optional)	1
4	Pump	1
5	Pump unions	2
7	GFCI (115V US/CA)	1
8	Slice valves	2
9	Hose bib drain	1
10	ControlMySpa Module (optional)	1

**CELEBRITY HOT TUBS TROUBLESHOOTING GUIDE**

**PLEASE NOTE:** The following corrective actions may be performed by the spa owner. If the trouble cannot be corrected in the steps below, please contact your authorized dealer for service. (Improper servicing by an unauthorized service provider or spa owner could result in damage not covered by the warranty and could cause serious injury.)

**EQUIPMENT WILL NOT OPERATE**

- Check the control panel LCD window for diagnostic code.
- 240V Spas: Check the circuit breaker on the main circuit panel.
- 120V Spas: Check the GFCI power cord and reset if necessary (see IMPORTANT SAFETY INSTRUCTIONS at beginning of manual).
- Check the condition of the power cord.

**INADEQUATE JET ACTION**

- Be sure the shut-off valves are completely open.
- Open the jets by turning the jet face to allow for maximum water flow.
- Check for obstruction or restrictions at suction guard(s) or filters, such as leaves, etc.
- Check to ensure water is at proper level and add water if needed.

**NO HEAT**

- Check temperature displayed in the LCD window for desired temperature setting.
- Inspect the filter cartridge for dirt and debris.
- Check that the water is at proper level, 4" (10cm) below the lip.
- Check to make sure spa is in High Range. See above for programming the temperature range.
- Lower ambient temperatures may result in heat loss.

**NOTE:** Do not expect instant hot water from the jets. It will take the heater 12-24 hours to heat the water to the temperature you desire.

**LIGHT DOES NOT WORK**

- Press the LIGHT pad on the control panel.
- Check connections of light wires.

**LCD DIAGNOSTIC MESSAGES**

The advanced technology built into the spa allows it to perform a number of self-diagnostic system checks and it can display a variety of messages in the LCD window on the control panel.

**TOO COLD:** Freeze protection has been activated, and no corrective action is required. This is normal on a fresh fill.

**WATR TOO HOT:** One of the sensors has reached 110°F (43°C). Do not enter the water; contact your dealer for service.

**HTR FLOW LOSS:** There is not enough water flow through the heater. Clean or install new filter(s) and check that the slice valves are fully open. Call dealer for service.

### **CELEBRITY HOT TUBS TROUBLESHOOTING GUIDE**

**HTR MAY BE DRY:** There is little to no water flow through the heater. Check that the slice valves are fully open. Contact dealer for service.

**HTR TOO HOT:** One of the sensors has reached 118°F (48°C). Do not enter the water. Contact dealer for service.

**PRES BTTN TO RSET:** Some codes require a button press or power to be removed and restored.

**SNSR BALANCE:** The sensors are reading a temperature of 2°F (17°C) or more. This can occur on a fresh fill, no corrective action required. Contact dealer for service.

**SNSR A:** Sensor A is non-functional. Contact dealer for service.

**SNSR B:** Sensor B is non-functional. Contact dealer for service.

**MEM FAIL:** There is a problem with the firmware. Contact dealer for service.

**MEM RSET:** Memory has failed. Contact dealer for service.

**CLOK FAIL:** Clock has failed. Contact dealer for service.

**CNFG FAIL:** Contact dealer for service.

**STUK PUMP:** Water may be overheated (DO NOT ENTER THE WATER). Contact dealer for service.

**HOT FALT:** A pump may be stuck on. Contact dealer for service.

### **CELEBRITY HOT TUBS TROUBLESHOOTING GUIDE**

#### **PLEASE NOTE:**

The following corrective actions may be performed by the spa owner. If the trouble cannot be corrected in the steps below, please contact your authorized dealer for service. (Improper servicing by an unauthorized service provider or spa owner could result in damage not covered by the warranty and could cause serious injury.)

#### **EQUIPMENT WILL NOT OPERATE**

Check the control panel LCD window for diagnostic code.

240V Spas: Check the circuit breaker on the main circuit panel.

120V Spas: Check the GFCI power cord and reset if necessary (see IMPORTANT SAFETY INSTRUCTIONS at beginning of manual).

Check the condition of the power cord.

#### **INADEQUATE JET ACTION**

Be sure the shut-off valves are completely open.

Open the jets by turning the jet face to allow for maximum water flow.

Check for obstruction or restrictions at suction guard(s) or filters, such as leaves, etc.

Check to ensure water is at proper level and add water if needed.

#### **NO HEAT**

Check temperature displayed in the LCD window for desired temperature setting.

Inspect the filter cartridge for dirt and debris.

Check that the water is at proper level, 4" (10cm) below the lip.

Check to make sure spa is in High Range. See above for programming the temperature range.

Lower ambient temperatures may result in heat loss.

**NOTE:** Do not expect instant hot water from the jets. It will take the heater 12-24 hours to heat the water to the temperature you desire.

### **LIGHT DOES NOT WORK**

- Press the LIGHT pad on the control panel.
- Check connections of light wires.

### **LCD DIAGNOSTIC MESSAGES**

The advanced technology built into the spa allows it to perform a number of self-diagnostic system checks and it can display a variety of messages in the LCD window on the control panel.

**TOO COLD:** Freeze protection has been activated, and no corrective action is required. This is normal on a fresh fill.

**WATR TOO HOT:** One of the sensors has reached 110°F (43°C). Do not enter the water; contact your dealer for service.

**HTR FLOW LOSS:** There is not enough water flow through the heater. Clean or install new filter(s) and check that the slice valves are fully open. Call dealer for service.

**HTR MAY BE DRY:** There is little to no water flow through the heater. Check that the slice valves are fully open. Contact dealer for service.

**HTR TOO HOT:** One of the sensors has reached 118°F (48°C). Do not enter the water. Contact dealer for service.

**PRESS BTTN TO RSET:** Some codes require a button press or power to be removed and restored.

**SNSR BALANCE:** The sensors are reading a temperature of 2°F (17°C) or more. This can occur on a fresh fill, no corrective action required. Contact dealer for service.

**SNSR A:** Sensor A is non-functional. Contact dealer for service.

**SNSR B:** Sensor B is non-functional. Contact dealer for service.

**MEM FAIL:** There is a problem with the firmware. Contact dealer for service.

**MEM RSET:** Memory has failed. Contact dealer for service.

**CLOK FAIL:** Clock has failed. Contact dealer for service.

**CNFG FAIL:** Contact dealer for service.

**STUK PUMP:** Water may be overheated (DO NOT ENTER THE WATER). Contact dealer for service.

**HOT FALT:** A pump may be stuck on. Contact dealer for service.

## **HOW TO PROLONG THE LIFE OF YOUR HOT TUB**

There are some simple steps you can take to prolong the life of your hot tub. Please follow the guidelines listed below to ensure the most trouble-free and enjoyable use of your spa.

Rinse your feet.

Please remember to rinse your feet before getting into the hot tub. This will help prevent sand and dirt from entering the plumbing system where it can clog valves and plug filters.

### **Use suction socks.**

Please also use a suction sock to further reduce the number of debris that can enter the plumbing system.

### **Maintain your valves.**

If one of your valves begins to feel hard to turn, please remove the valve and rinse it. To remove the valve, please turn the power off to the spa and remove the handle for

the valve. Turn the top portion of the valve cap counterclockwise to expose the valve insert. Using the valve stem, please pull straight up on the insert. Rinse the valve and put back the insert into the sleeve and then replace the cap and handle. If the valve is scratched, it is a good idea to use a fine grit sandpaper to smooth the valve insert before reinstallation.

### **Keep the cover on**

Always keep your hot tub cover closed when the spa is not in use. This helps prevent unwanted debris from entering the hot tub and prevents sun exposure that could damage the surface and the jets of the hot tub. For full warranty coverage, please note the spa must remain covered at all times when not in use.

### **Keep the water clear and balanced!**

Water chemistry is another important part of spa ownership. Please be sure to use only factory recommended products. In addition, please make sure you maintain proper pH and sanitizer levels. Drain and refill your hot tub with fresh water every 3 to 4 months. On a regular basis, please use a spa vacuum to remove dirt and sand that can be seen on the floor of the hot tub.

NOTE: Damage to the spa surface and equipment due to the use of trichlor chlorine, or other harsh chemicals not recommended by Marquis is not covered under warranty.

## **WEEKLY MAINTENANCE**

### **Removing Debris**

Remove any debris and leaves from the skimmers and suction guard(s) on the inside of the spa. Blocked intakes can impede the flow of water through the jetting system.

### **Water Level**

Replenish the water level if necessary, so that it is approximately 4" (10cm) below the top of the lip. (See STARTING YOUR SPA.) Low and high-water levels can damage your spa. It is important to check your water level often.

## **MONTHLY MAINTENANCE**

### **Filter Care**

We cannot stress enough the importance of a clean filter for proper water filtration. Dirty filters can restrict water flow, cause hazy water, and prevent your chemicals from working properly. Dirty filters can also cause low flow from jets, poor water clarity and sensors to activate error codes. It is important to clean filters regularly. Many water treatment products clear or clarify the water by clumping microscopic particles and minerals together so that these larger particles can be effectively trapped in the filter. A filter clogged with debris and calcium deposits does not trap particles properly. Soak your filter cartridges in *Filter Cleaner* monthly.

**NOTE:** Filters and filter lids do not qualify for labor coverage. These parts can be purchased or exchanged under warranty at your authorized Holiday Park Hot Tubs dealer.

Leakage Detection

**SPA MAINTENANCE**

Open the equipment door and check for signs of water leakage around the pump(s). Pump seals wear out over time, especially with improper water chemistry. Early detection of pump seal failure can significantly reduce repair costs. Pump seals, heater gaskets and pump gaskets must be checked each month to ensure they are not leaking. Further damage caused by a leak from any component is not covered under the warranty.

**EVERY THREE TO FOUR MONTHS****Draining and Filling the Spa**

The average spa needs to be drained every three to four months. After months of continually adding chemicals to the water and introducing body oils and lotions, the water can be difficult to manage, and chemicals are not as effective as usual. You may also notice excessive foaming. More frequent draining may be required depending on use.

**Draining the Spa**

- Turn off the power to the spa.
- Open the equipment compartment (see EQUIPMENT DIAGRAM). Remove the hose bib cap from the connection and attach a hose.
- Open the drain valve. Gravity causes the water to drain out of the hose.
- When the spa is empty, close the drain valve and remove the hose. Reinstall the hose bib plug.

**NOTE:** Keep the drain valve closed at all times except when draining the spa (do not rely on the cap to stop the flow of water). Not doing so could result in damage to the drain valve due to freezing water.

**Cleaning the Interior**

Once the spa is drained, clean the shell interior thoroughly – especially at the water line. We suggest *Glove Sponge* to clean without scratching.

Clean with *Spa Brite* and shine shell with *Gloss and Guard*. Use only chemicals recommended to you by your dealer or service agent. Bleach (diluted) is another recommended cleaning agent for the shell – other products should be avoided except as stated below.

To maintain the high gloss and elegant look of the shell, just follow these simple steps: For normal care and cleaning use soft cloth or sponge with *Gloss & Guard*. Rinse well and dry with a soft, clean cloth. Never use abrasive cleaners. Do not allow your acrylic surface to come into contact with products such as ketones or esters such as acetone or ethyl acetate (nail polish remover), Wintergreen oil (methyl salicylate), nail polish, dry cleaning solution or other chlorinated organic solvents, lacquer thinners, gasoline, aromatic solvents, citrus cleaners, pine oil, etc. Remove dust and dry dirt with a soft, damp cloth. Clean grease, oil, paint and ink stains with diluted isopropyl (rubbing) alcohol (do not let alcohol pool or remain on acrylic). Dry with a clean, soft cloth. Avoid using razor blades or other sharp instruments that might scratch the surface.

**NOTE:** Due to the high-gloss, fine finish of the acrylics, imperfections in the surface texture may occur. A natural aging process in acrylic can lead to a process called crazing. Fine spider web-like lines can form on the cosmetic surface of acrylic over time after exposure to the elements and chemicals. Crazing represents no structural weakening of acrylic and is not covered under the warranty. Fading, staining and discoloration may also occur but represent no structural degradation and are not covered under warranty.

**NOTE:** Do not leave an empty spa uncovered. Direct sunlight on the spa surface can cause severe damage or blemishing, cause fittings to discolor and can result in the voiding of any surface warranties.

### **Refill the Spa**

Fill the spa with fresh water from a garden hose and balance the water as described in the Water Treatment section. The use of a *Fill Filter* is recommended when filling especially in areas of high mineral content in the water. Attach to the end of a garden hose to filter out any grit and sediment that could accumulate in the spa and potentially scratch the spa surface.

## **AS NEEDED MAINTENANCE**

### **Cover Care**

It is recommended that you use *Cover Cleaner* to keep the cover clean and conditioned. Proper care of the cover increases the life and keeps it looking great in even the harshest conditions.

**NOTE:** Do not use regular household products or products that contain silicone, alcohol, steel wool, or bleach.

1. Remove the cover from the spa and gently lean it against a wall or fence.
2. Use a garden hose to spray the cover and loosen and rinse away dirt or debris.
3. Use a large sponge and/or soft bristle brush with a very mild soap solution. Scrub the vinyl top in a circular motion. Rinse vinyl clean before a soap film has a chance to dry.
4. Scrub the perimeter of the cover and side flaps. Rinse clean with water.
5. Rinse off underside of cover with water only (no soap) and wipe clean with a dry rag.
6. Use *Cover Cleaner* to condition the top of the cover after cleaning.

### **Headrest Care**

To increase the life of your headrest, remove and replace them with care only when necessary.

### **Remove Headrest**

Slip your fingers under each end of the interior headrest part and gently pull straight towards you. Damage caused to attachments due to improper removal is not covered

**SPA MAINTENANCE**

under warranty. Pillows and attachments are warranted to be free of defects at delivery only.

**Exterior Care**

Clean the exterior of the spa with a mild soap and water solution. Cleaners that contain alcohol or high levels of solvents, along with Acetone, Nitrobenzene, and Cyclohexanol, can dissolve and discolor the DuraWood exterior.

**Excess Debris**

Grit and debris tracked into the spa should be removed with a spa vacuum.

**Water Line**

To avoid buildup of oils and lotions at the water line, clean the interior weekly or when needed. We suggest the Glove Sponge to clean without scratching. NOTE: Do not use the same brush or sponge to clean the exterior of the spa and the interior of the spa. Soap and other product residue used on the outside of the spa can cause foaming of the spa water and scratches to the spa surface if used on the inside of the spa.

**SUSPENDED USE OR WINTERIZING THE SPA**

If you decide to discontinue the use of your spa for any extended period of time, we suggest you follow the steps below.

**NOTE:** During long periods of inactivity, damage can occur to equipment from condensation within the equipment compartment. Failure to follow these instructions during freezing conditions will result in cracked fitting(s) and glue joints, and other damage.

1. Turn off the power to the spa.
2. Drain the spa. (See DRAINING AND REFILLING THE SPA.)
3. Remove all residual water from the seating and footwell. If necessary, bail out the remaining water then dry the spa with towels. A wet/dry vacuum is recommended for best results.
4. Using the wet/dry vacuum, place vacuum nozzle over each jet nozzle to remove water from plumbing lines, starting with the highest jet and finishing with the lowest jet. NOTE: The spa is equipped with a zone control valve which is used to divert water between different jet zones. The valve must be "open" to the particular jets you are vacuuming.
5. Unscrew the pump plug(s) from the pump(s). (See STARTING YOUR SPA.)
6. Again, using the wet/dry vacuum, place nozzle over the exposed pump opening(s) to remove excess water. The pump(s) should be removed from the spa and stored in a climate controlled room.
7. Clean the spa interior.
8. Clean the filter cartridges.
9. Reinstall the cover and lock in place.

**NOTE:** Direct sunlight on the spa surface can cause severe damage or blemishing and can result in the voiding of any surface warranties.

**VACATION CARE INSTRUCTIONS**

Short time periods: 3-5 days

Adjust the pH (see WATER CARE).

Sanitize the water by following the shock procedures.

Lock your spa cover in place with cover locks.

Upon return, shock sanitizes water.

Long time periods: 5-14 days

1. One day before leaving, set the temperature to its lowest level (approximately 80°F, 27°C).
2. Adjust pH as needed.
3. Shock sanitize water.
4. Upon return, shock sanitizes water.
5. Return temperature to original setting.
6. Test water chemistry and adjust as necessary.

## IMPORTANT CHEMICAL SAFETY PROCEDURES

1. Always keep chemicals out of reach of children.
2. Read product labels carefully prior to use.
3. When dissolving, always add chemicals to water, do not add water to chemicals. Some dry chemicals should be dissolved prior to adding them to the spa. Using a clean container, dip some water from the spa. Mix until dissolved, then add to circulating water.
4. **CAUTION:** Do not mix chemicals together. Add them separately to the spa water.
5. All chemical products should be stored in a cool, dry, well-ventilated area where the average temperature does not exceed 100°F (32°C). Keep storage area clean of debris such as rags, newspaper, and combustible materials.
6. Keep chemicals away from open flame or other heat source. Do not smoke near chemicals. If a dry chlorine chemical fire should occur, use water only. Do not use a dry chemical fire extinguisher to attempt to put out the fire.
7. When adding chemicals, always keep the water circulating in the spa with jets in a downward circular pattern for better chemical distribution. Add chemicals to the spa water one at a time. Allow several minutes between any new chemical additions using the jet action to evenly distribute throughout the spa.
8. It is important to leave the spa cover open for 20-30 minutes while shock treating your spa to avoid damage. Do not leave spa unattended while cover is open. Damage such as discoloration or brittle vinyl due to chemical damage is not covered under the warranty.
9. After adding chemicals, wait the amount of time recommended on the chemical container before retesting your water for an accurate reading. Retest your spa water before using.
10. If you have any questions or concerns about the correct procedures for handling chemicals, please contact your authorized Marquis® dealer.

**CAUTION:** Damage to the spa surface and equipment due to the use of trichlor chlorine, or other harsh chemicals not recommended by Marquis is not covered under warranty.

## WATER CARE

There are three things necessary for clean safe water:

1. **CIRCULATE:** Water has to be circulated regularly; it cannot be stagnant.
2. **FILTER:** Water has to be filtered to remove particulates and debris.
3. **SANITIZE:** Water has to be sanitized to kill organisms like algae, bacteria and virus.

It is critical to maintain proper water balance to protect the spa heater and other components from damage. Damage to the spa surface and equipment caused by poor chemical or harsh chemical treatment is not covered under the warranty. Discoloration of jet faces, valves and controls are an indication of poor chemical maintenance or exposure to the sun.

Jet inserts and valves do not qualify for labor coverage. These parts can be purchased or exchanged under warranty at your authorized Marquis® dealer. Gaskets and seals are not covered under the warranty. The control system in your Marquis spa will automatically circulate and filter. (See SPA CONTROL OPERATION, ConstantClean™ and SmartClean™ sections.) The sanitation requires minimal effort if done consistently and properly.

To sanitize spa water, three things are required:

1. **BALANCE:** The water must be balanced so the sanitizer can work and spa equipment is protected.
2. **SHOCK:** Shock to oxidize organics and maximize sanitizer efficiency.
3. **SANITIZE:** Always maintain a proper level of sanitizer.

## **UNDERSTANDING WATER BALANCE**

Water balance is the interrelation of factors that determine the quality of the spa water. The effectiveness of chemicals and other additives are dependent on all these factors working together or “in balance”. The primary elements to water balance are the calcium hardness, total alkalinity and pH. Always use water treatment products recommended for use in a Marquis spa.

### **pH Balance**

Keeping the pH balanced is the most critical component of water balance. Calcium hardness and total alkalinity act as buffers to stabilize the pH. When they are properly adjusted, the pH will be stable and easy to maintain. The pH is a measure of the relative acidity and basicity of the water. The ideal pH range is 7.4 - 7.6. When the pH falls below 7.2, the water can become corrosive. Low pH can cause damage to metal in the control system and heater, excessive sanitizer consumption, and skin irritation. A pH above 7.8 can be scale forming and allow metals or minerals in the water to form deposits and stain spa surfaces. pH above 7.8 can also cause eye and skin irritation.

### **Total Alkalinity**

Alkalinity acts as a buffer to prevent the pH from changing as other substances are added to the water. Stability of the pH is directly related to the alkalinity. The alkalinity should be between 80 - 140 ppm. Alkalinity below 80 ppm makes it difficult to stabilize the pH. Alkalinity above 140 ppm may increase the pH and cause cloudy water, scaling, and decreased efficiency of the sanitizer.

*Note: Alkalinity Increaser & pH Increaser and Alkalinity & pH Decreaser will affect both the pH and alkalinity. Generally, smaller additions will change the pH and have a very minor effect on the alkalinity. Larger additions will also affect the pH but will have a much greater effect on the alkalinity. (Example: If the pH is very high and the alkalinity is within range, adding a few smaller doses of pH and alkalinity Decreaser instead of one large dose will reduce the pH with little effect on the alkalinity.)*

## **Calcium Hardness**

Do not use soft water in your spa. It is critical to have calcium in your water. The ideal range of calcium is between 150 – 250 ppm. The calcium hardness is normally adjusted when filling or refilling after draining the spa. High calcium levels can cause scale buildup on spa surfaces and equipment. Your spa can be protected against high calcium by using Metal & Stain Remover per the directions on the container. Low calcium levels can cause spa water to become highly corrosive and damaging to the equipment components and plumbing. To raise calcium levels, use Calcium Hardness Increase.

## **SPA WATER SHALL BE TESTED AND TREATED IN ACCORDANCE WITH ALL LOCAL CODES**

### **BALANCE**

When initially filling or refilling your spa, follow these steps to achieve proper water balance.

**IMPORTANT!** Always follow instructions on the chemical container when adding chemicals.

Test the spa water using a test strip or test kit. Determine the pH and alkalinity of the water.

If adjustments are needed for the pH and/or alkalinity, always balance the alkalinity before balancing the pH. The product(s) you should use to adjust pH and/or alkalinity are pH Increaser, Alkalinity Increaser or pH & Alkalinity Decreaser. Make any additions per the directions on the bottle and then test and repeat if necessary, until all readings are in the desired range.

Increase the calcium hardness if necessary.

### **SHOCK**

#### **Initial Treatment**

Shock the spa using granular Chlorine Sanitizer or non-chlorine Spa Shock. Add directly to the spa per the instructions on the container. For the initial treatment, Chlorine Sanitizer is preferred as it will also establish a residual of sanitizer. You may shock weekly using non-chlorine shock for low chlorine usage.

#### **Maintenance Treatment**

Once bacteria and other wastes are neutralized by the sanitizer, they stay in the water unless oxidized or shocked. Often called chloramines or bromamines, they create dull, cloudy water and can cause odor and eye or skin irritation. Shock treatment rids your spa of these wastes for clear, sparkling water. Shocking with non-chlorine Spa Shock or granular Chlorine Sanitizer is recommended once a week or whenever the water appears dull or cloudy or has a strong odor. Non-chlorine Spa Shock allows use of the spa 15 minutes after shock treatment.

**NOTE:** A strong bromine or chlorine odor typically indicates the spa needs to be shocked not that there is too much bromine or chlorine in the water.

A properly balanced spa that is shocked regularly will not have an odor.

### **SANITIZE**

### ConstantClean+ System (Optional)

The ConstantClean+ system utilizes a combination of sanitizers to increase water quality and significantly decrease maintenance. The combination of a In-Line Mineral Cartridge\* and the factory installed ozonator greatly reduce the amount of sanitizer required. Instead of the normal 3 - 5 ppm of bromine, you may only need to maintain 1 - 2 ppm of bromine.

NOTE: The use of Spa Frog® or @ease floating cartridges is recommended. Do not use other floating chemical dispensers or Biguanide. Damage to the spa shell and other internal components can occur.

\* The built-in sanitation system is not available in some international markets. However, the ozone system is available on all spa models in all countries. Please see your dealer for recommended alternative treatment method if the built-in sanitation system is not available.

### BUILT-IN SANITATION SYSTEM\*

After shocking the spa water with Chlorine Sanitizer granules or 1-Step Brominating Granules, bring the spa water to operating temperature. Then install the In-Line cartridges.

### ADJUST THE MINERAL CARTRIDGE

Remove the protective cellophane wrap from the In-Line mineral cartridge. While holding the bottom of the cartridge, turn to the top until the number six appears in the setting window.

NOTE: The mineral cartridge should be replaced every three to four months. You will still feel the "spent" minerals inside, but they are no longer effective, and the cartridge needs to be replaced. It is recommended to drain and refill the spa at the same time you replace the mineral cartridge.

### ADJUST THE BROMINE OR CHLORINE CARTRIDGE

Remove the protective cellophane wrap from the Spa Frog® bromine or @ease w/Smart Chlor cartridge. Finding the right setting for the sanitizer cartridge will require monitoring your usage for the first few weeks. Begin with an initial setting based on the chart below and monitor sanitizer levels daily for the first week or so, adjusting the cartridge by one setting per day until a 3 - 5 ppm level has been achieved. To adjust cartridge, remove from system and turn to the next highest setting if the sanitizer level is low or the next lower setting if the sanitizer level is high. The sanitizer cartridge needs to be replaced when empty between two and four weeks. Always maintain 3 - 5 ppm of bromine or chlorine.

### *Suggested Initial Bromine or @ease w/Smart Chlor Cartridge Settings*

Daily filter time	Spa Gallons			
	-250	250-300	300-400	400-500
One hour	2	2	3	4
Two hours 2	2	2	3	
Four hours 1	1	2	2	

### INSTALL THE CARTRIDGES

Locate and remove the cartridge holder cap on the top lip of the spa. Push down and turn the holder counterclockwise to unlock. Lift holder out. Snap the Spa Frog® or @ease mineral cartridge into the area of the holder marked "MINERALS" (top portion), making sure to line up the indentation near the top of the cartridge with the raised line on the holder. Then snap the Spa Frog® bromine or chlorine cartridge into the area of the holder marked "BROMINE/ CHLORINE". Be sure to line up the indentation on the cartridge with the raised line on the holder. After cartridges are snapped in, return the holder, push down, and then turn clockwise to lock into place. Replace the cap.

**CAUTION:** Hand-tighten only; avoid over tightening; avoid bending the holder to help prevent damage to the holder. Damage caused due to improper removal or installation of chemical cartridge holder is not covered under the warranty. Cartridge holder is warranted to be free from defects at time of delivery of spa. Chemical cartridge holders do not qualify for labor coverage. These parts can be purchased or exchanged under warranty at your authorized Marquis® dealer.

## **REMOVE THE CARTRIDGES**

Reverse above procedures to remove cartridges.

## **WATER CARE REGIMEN**

Marquis SpaCare™ products are classified by easy to follow usage guidelines. The information below indicates whether the product should be used daily, weekly, monthly, when filling, or as needed – if special water conditions arise.

### **DAILY**

Sanitizer

Maintain 1 - 2 ppm of bromine, at ease or chlorine at all times.

### **WEEKLY**

**Spa Shock**

Sanitizer combines with bacteria and neutralizes sanitizer/bacteria on contact. However, the used sanitizer/bacteria particle is still present in the spa water. Used sanitizer in the water emits an odor and causes cloudy water. To oxidize, or rid the spa of this used sanitizer, you must shock the spa once a week. For best results, and to protect your spa cover leave the spa cover open for a minimum of 20 minutes after shocking the water.

NOTE: Additional shock may be necessary if the spa is under heavy use. For @ease w/Smart Chlor (for use in the US only) you will only need to shock as needed or monthly.

## **AS NEEDED PRODUCTS**

pH Increaser, Alkalinity Increaser pH & Alkalinity Decreaser

These three products work to raise or lower the pH and alkalinity in the spa. They are only needed if the test strip indicates the levels are not in the ideal ranges.

**Water Clarifier**

Microscopic particles can pass through the spa filter and create cloudy water. The use of *Marquis SpaCare™ Water Clarifier* combines these microscopic particles into larger particles that can be trapped in the filter to clear cloudy water.

### **Spa Defoamer**

If foam appears in your spa, the action of the jets will keep it from dissipating. The use of *Marquis SpaCare™ Spa Defoamer* instantly rids your spa water of foam.

### **Metal and Stain Remover**

Metal and Stain Remover will remove metals such as iron and copper from spa water.

## **WATER CARE TROUBLESHOOTING GUIDE**

NOTE: If you request a service call and no problem is found with the spa or the problem is not covered by warranty (i.e. chemical damage), you will be charged at the regular service rate.

P: Problem

S: Solution

### **Cloudy Water**

P: Inadequate filtration or dirty filter.

S: Ensure that the filter is securely installed. Clean or replace filter. Increase the length of clean up and/or filter cycles.

P: Water is not balanced.

S: Test water and adjust pH, alkalinity, and sanitizer as needed. Shock to oxidize and destroy organics in the water.

P: Unfiltered particles or chemically saturated. S: Use Water Clarifier to combine particles.

P: High total dissolved solids

S: Drain, clean, and refill the spa.

### **Chemical Odor**

P: Too many chloramines/bromamines in the water.

S: Treat water with Spa Shock, then adjust sanitizer level as necessary.

P: Dull looking water, difficult to manage. High total dissolved solids (TDS) may be the cause.

S: Drain, clean and refill with fresh water.

### **Musty Odor**

P: Not enough sanitizer in water – bacteria or algae in water.

S: Add sanitizer as necessary and shock. Readjust sanitizer level if necessary.

### **Yellow Water**

P: Low pH and/or low alkalinity.

S: Test and adjust pH with pH and Alkalinity Increase. Adjust alkalinity if necessary.

**Foaming**

P: High concentration of body oils, lotions or soaps, as well as excessive organics.

S: Use Spa Defoamer and adjust pH and sanitizer as needed.

**Scum Line in Spa**

P: Body oils and dirt.

S: Use Glove Sponge to clean the spa. Test and adjust the sanitizer and pH if necessary. Increase the clean-up cycle.

**No Sanitizer Reading**

P: Sanitizer level is too low.

S: Shock and/or adjust sanitizer cartridge until the sanitizer registers in the recommended range.

P: Test strip remains "white" even after sanitizer has been added.

S: Sanitizer level could be extremely high. It can bleach the reagents on the test strip and give a false reading. Remove spa cover and activate jets and air control. Allow jets to run for 30 minutes. Test water to see if desired level has been reached. Adjust sanitizer cartridge to reduce bromine or chlorine level.

**High Sanitizer Reading**

P: Too much chlorine or bromine added or dispensed into the spa.

S: Remove spa cover and activate jets and air control. Allow jets to run for 30 minutes. Test water to see if desired level has been reached. Adjust sanitizer cartridge to reduce bromine or chlorine level.

**Eye or Skin Irritation**

P: Contaminants or excessive amount of chloramines/bromamines in water.

S: Treat water with Spa Shock. Adjust sanitizer level.

P: pH is low.

S: Adjust as needed.

**Corrosion of Metal**

P: Low pH.

S: Adjust pH with pH and Alkalinity Increase.

**Green Water/Algae**

P: Low sanitizer level or high pH.

S: Adjust pH, shock and/or adjust sanitizer cartridge as necessary.

**Erratic Ph**

P: Alkalinity and/or calcium hardness are too low causing pH "bounce".

S: Test and adjust alkalinity and/or calcium hardness to bring them into the ideal range.

**WHAT THE MARQUIS  
CORP. LIMITED  
WARRANTY COVERS**

What the Marquis Corp. Limited Warranty Covers  
Marquis Corp. warrants that our products will be free from defects in materials and workmanship for the term set forth exclusively in this warranty. Accessories purchased from Marquis Corp. or a Marquis Corp. authorized Marquis® dealer and added to the spa after manufacture of the spa are not covered under this warranty but may have other warranties. Refer to owner's manual for proper use, maintenance and installation of your spa. The Marquis® Limited Warranty, provided by this Owner's Protection Plan, is made only to the original purchaser of the spa and is not transferable.

**10 YEAR STRUCTURE**

The reinforced structure is warranted for **10 years** not to leak. Fittings and attachments are not included.

**7 YEAR SURFACE**

The acrylic surface is warranted for **seven years** against blisters, cracks and delamination. The use of a non-Marquis® Weathershield™ cover will void this warranty.

**5 YEAR PLUMBING**

Plumbing and fittings are warranted against water loss for **five years**. Warranty coverage does not include gaskets or seals.

**5 YEAR EQUIPMENT**

Electronic equipment is warranted against defects in materials and workmanship for **five years**. Equipment includes PC boards, pumps, control panels, heater and heat sensors. MicroSilk® system and associated components has a **three year parts** and labor warranty. Audio system and associated components have a separate warranty.

**5 YEAR EXTERIOR**

The synthetic skirt and DuraBase™ exterior are warranted against cracking and peeling for **five years**. All Panels are covered under a **two-year** limited warranty, beginning on the date of manufacture.

**2 YEAR COMPONENTS**

The ozonator is warranted against defects in material and workmanship for **two years**.

## 1 YEAR PART

LED lights, valves, spa cover, jet inserts, in-line sanitation system and overlays are covered for one year. These parts do not qualify for labor coverage under this warranty.

Fuses, filter, filter lid, cushioned headrests, chemical cartridge holders and other items not specifically mentioned in this warranty are warranted to be free from defects in materials and workmanship at time of delivery.

These parts do not qualify for labor coverage under this warranty. The audio and audio components have a one-year warranty and includes parts and labor.

Please take a moment to register your warranty. You can register online at <http://www.marquisspas.com>, click on owner login or mail in the warranty registration card attached to this manual. For warranty information outside of the USA and Canada, please refer to your country's Marquis Spas'™ Distributor. Your first resource for warranty work, questions or claims is through the factory authorized Marquis Spas dealer you purchased the product from. Your dealer will support you in the life of your product and will have the best recommendation for service, water care, maintenance and repairs.

General provisions applicable to all parts covered by this warranty.

1. The spa must be set on a solid level surface that is sufficient to support the entire length and width of the spa. Standard building practices must be followed. Damage caused by failure to have a leveled and supported foundation under the spa is not covered under warranty. The manufacturer does not warrant problems associated with prolonged exposure to the sun and/or use of any sanitization or ozone system not approved by the manufacturer.
2. Any alteration to any system, either electrical, plumbing, or mechanical, or overuse of chemicals, or any other problems caused by external sources are not covered under warranty. Other exclusions may apply, see limitations for details.
3. Damage caused by acts of nature, poor water chemistry, and/or improper maintenance will not be covered under this warranty. Alterations or replacements of components installed in the spa that are not purchased and/or approved by the MANUFACTURER, including incorrect wiring, will terminate the complete spa warranty.
4. The warranty period starts on either the day of delivery to the customer or eighteen (18) months from the date of manufacturing, whichever date comes first.

## **PERFORMANCE**

In the event of any defect covered by this LIMITED warranty, a Marquis, authorized agent will correct such defect within the terms and conditions contained herein. There will be no charge for parts or labor within the above terms. However, travel charges that occur will not be covered under terms and conditions by the warranty. If it is determined by May Marquis Spas that the repair of the product is not feasible, a replacement spa equal to the value of the original purchase price will be provided. Cost for removal of the defective spa and delivery and installation of the replacement spa is the responsibility of the homeowner and will not under any circumstances be covered by Marquis Spas™.

**LIMITATIONS**

This warranty is void if this spa has been subjected to alteration, misuse, or repairs have been performed by anyone other than an authorized agent of Marquis Spas. Misuse or abuse is defined as: use of the spa in a nonresidential application, water temperature outside the range of 32 °F to 110 °F, damage caused by clogged or dirty filter cartridges, damage to the spa from an absence of a hard cover, damage to components from improper pH, use of any type of acid, or from chemical imbalance. ACTS OF NATURE are not covered under this warranty. NOTE: Warranty on 50 Hz spas excludes labor. (Outside US and Canada)

**DISCLAIMERS**

There are no additional warranties, express or implied, which extend beyond the terms of this limited warranty. Marquis Corp. makes no warranty on the merchantability of the goods or the fitness of the goods for a particular purpose.

No other person or entity has been authorized to make any warranty, representation or promise of performance not included in this express written warranty, and Marquis Corp. shall not be bound by any such additional warranty, representation or promise.

This warranty gives you specific legal rights. You may also have other rights that may vary from state to state



Marquis is a registered trademark of Marquis Hot Tubs, LLC. Marquis reserves the rights to make product modifications and enhancements.

[MarquisSpas.com](http://MarquisSpas.com)

